



LE
SANCTUAIRE D'ALÉA ATHÉNA
A TÉGÉE
AU IV^e SIECLE

FOUILLES DE L'ÉCOLE FRANÇAISE D'ATHÈNES

LE
SANCTUAIRE D'ALÉA ATHÉNA

A TÉGÉE
AU IV^e SIÈCLE

PAR

CHARLES DUGAS

MAÎTRE DE CONFÉRENCES A L'UNIVERSITÉ DE MONTPELLIER
ANCIEN MEMBRE DE L'ÉCOLE FRANÇAISE D'ATHÈNES

JULES BERCHMANS ET MOGENS CLEMMENSEN

SCULPTEUR
ANCIEN MEMBRE DE L'ÉCOLE FRANÇAISE D'ATHÈNES

ARCHITECTE

ATLAS

DE 116 PLANCHES

PARIS

LIBRAIRIE ORIENTALISTE PAUL GEUTHNER

13, RUE JACOB (VI^e)

—
1924



TABLE DES PLANCHES

Dans les planches reproduisant des dessins au trait le système suivant a été adopté pour la désignation des sujets : lorsque les figures d'une planche représentent divers aspects du même bloc, chacun de ces aspects est simplement désigné par une lettre minuscule; lorsque des blocs différents sont représentés sur la même planche, chaque bloc est désigné par une lettre majuscule, et ses divers aspects distingués par des minuscules écrites à la suite de la majuscule. — Dans les planches reproduisant des vues photographiques chaque sujet est désigné par une lettre majuscule que suit entre parenthèses, s'il y a lieu, le numéro de notre catalogue.

- PL. I-II. — Plan de situation.
PL. III-V. — Plan du temple, état actuel.
PL. VI-VIII. — Façade et coupes des fondations.
PL. IX-XI. — Plan restauré du temple.
PL. XII-XIV. — Façade Est et coupe transversale devant le pronaos.
PL. XV-XVII. — Long côté.
PL. XVIII-XX. — Coupe longitudinale.
PL. XXI-XXVI. — Coupe sur le péristyle.
PL. XXVII-XXVIII. — Les murs du temple (assises superposées).
PL. XXIX¹. — Blocs de l'euthyntéria : A, bloc de l'euthyntéria du soubassement : a, face supérieure; b, face antérieure; c, face latérale; B, bloc de l'euthyntéria de la rampe Est : a, face supérieure; b, face antérieure; c, face postérieure; d, face latérale; C, coupe de l'euthyntéria du temple montrant le niveau de cette dernière par rapport à l'euthyntéria de la rampe.
PL. XXX. — Blocs des degrés : A, premier degré : a, face supérieure; b, face antérieure; c, face latérale gauche; B, second degré : a, face inférieure; b, face latérale.
PL. XXXI. — Blocs du soubassement : A, bloc d'angle intérieur du soubassement : a, face supérieure; b, face vers l'extérieur; c, face vers l'intérieur; B, fragment d'un bloc d'angle du stylobate : a, face latérale; b, face inférieure.
PL. XXXII. — Bloc d'angle du stylobate : a, face supérieure; b, face antérieure; c, face latérale.
PL. XXXIII. — Bloc du stylobate : a, face supérieure; b, face inférieure; c, face latérale vers l'intérieur.
PL. XXXIV. — A, bloc du stylobate : a, face supérieure; b, face inférieure; B, tambour de colonne A (cf. appendice II), face inférieure.
PL. XXXV. — Chapiteau de l'ordre extérieur : a, face antérieure; b, face inférieure; c, face supérieure.
PL. XXXVI. — A, chapiteau de l'ordre extérieur, face inférieure; B, chapiteau d'angle, face supérieure.
PL. XXXVII². — Profils : A, du chapiteau de la péristasis; B, du chapiteau du pronaos; C, de la cannelure de la péristasis (en bas); D, de la cannelure de la péristasis (au-dessous du chapiteau); E, de la cannelure du pronaos (au-dessous du chapiteau).
PL. XXXVIII. — Bloc d'angle de l'architrave de l'ordre extérieur : a, face sur le long côté; b, face sur le petit côté; c, face postérieure; d, face supérieure.
PL. XXXIX. — A, bloc de l'architrave de l'ordre extérieur : a, face antérieure; b, face latérale; c, face supérieure; d, plan des gouttes; B, triglyphe d'angle de l'ordre extérieur, face inférieure.
PL. XL. — Bloc d'angle de la contre-architrave : a, face antérieure; b, face postérieure; c, face supérieure; d, face inférieure.

1. Corriger cette planche en supprimant la lettre A inscrite par erreur à gauche du bloc B a.

2. Corriger cette planche en redressant verticalement, dans le profil de chapiteau A, la ligne de l'abaque.

LE SANCTUAIRE D'ALÉA ATHÉNA

- Pl. XLI — Bloc de la frise de l'ordre extérieur (petits côtés) : a, face antérieure; b, face latérale gauche; c, face latérale droite; d, face supérieure.
- Pl. XLII. — Bloc de la frise de l'ordre extérieur : a, face antérieure; b, face latérale gauche; c, face supérieure; d, coupe horizontale; e, coupe verticale sur le triglyphe.
- Pl. XLIII. — Bloc d'angle de la frise de l'ordre extérieur : a, face sur le petit côté; b, face sur le long côté; c, face postérieure; d, face supérieure.
- Pl. XLIV. — Blocs de la corniche de l'ordre extérieur : Aa, face antérieure; b, face inférieure; c, face latérale; d, coupe; Ba, face supérieure; b, face latérale.
- Pl. XLV. — Coupe sur le fronton et blocs de la corniche : A et B, fragments de la corniche rampante du fronton; C, fragment de la corniche horizontale : a, face latérale; b, face supérieure avec empreinte de statue; D, autre fragment, face supérieure, avec trou de scellement pour les sculptures.
- Pl. XLVI. — Sima des longs côtés : a, face antérieure; b, coupe à côté de la tête de lion; c, coupe dans la tête de lion.
- Pl. XLVII. — A, sima des longs côtés près de l'angle : a, face antérieure; b, coupe dans la tête de lion; c, face supérieure; Ba, coupe de la sima avec face latérale de l'antéfixe; b, face antérieure d'un petit fragment de l'antéfixe; C, antéfixe faîtière : a, face antérieure; b, face latérale.
- Pl. XLVIII. — Tuiles : A, tuile plate : a, face supérieure; b, coupe transversale; c, face antérieure; d, face inférieure; e, coupe longitudinale; B, tuile couvre-joints : a, face supérieure; b, coupe longitudinale; c, face inférieure; d, coupe transversale; e, face antérieure; C, fragment de tuile avec lucarne, coupe.
- Pl. XLIX. — Blocs : A, du tympan Est : a, face antérieure; b, face latérale; c, face supérieure; B, du tympan Ouest : a, face latérale; b, face antérieure; c, face supérieure.
- Pl. L. — Trois blocs du tympan Ouest : A, face antérieure; B, face antérieure; Ca, face antérieure; b, face supérieure.
- Pl. LI. — A, parpaing du mur de la cella (partie haute) : a, face antérieure; b, face supérieure; c, face latérale; B, C, D, E : blocs de la sima du fronton : B, bloc du côté droit : a, face antérieure; b, face latérale; C, fragment de moulure; D, bloc du côté gauche : a, face antérieure; b, face latérale; E, bloc du côté gauche sous la base de l'acrotère : a, face antérieure; b, face latérale.
- Pl. LII. — Couronnements du péristyle : A, couronnement intérieur de la péristasis et couronnement extérieur du mur de la cella : a, face antérieure; b, face latérale; c, face supérieure; B, couronnement des petits côtés du péristyle (entre les solives) : a, face antérieure; b, coupe; c, face latérale; d, face supérieure (avec trou de scellement pour les soffites).
- Pl. LIII. — Poutre transversale du péristyle : a, face inférieure; b, face latérale droite; c, face latérale gauche; d, coupe (avec couronnement entre les solives devant le pronaos).
- Pl. LIV. — A et B, solives du péristyle (petits côtés) et du pronaos : Aa, face latérale; b, coupe; c, face inférieure; d, face inférieure d'un autre bloc (partie au-dessus de la corniche du pronaos ou de la poutre transversale); Ba, face latérale; b, face supérieure (partie se raccordant avec le couronnement); C, couronnement du péristyle (petits côtés) et du pronaos : a, face antérieure; b, face latérale; c, face supérieure (avec trous de scellements pour les soffites).
- Pl. LV. — Soffites du péristyle (longs côtés).
- Pl. LVI. — Soffite du péristyle (petits côtés) et du pronaos.
- Pl. LVII. — Chapiteau du pronaos : a, face antérieure; b, face inférieure; c, face supérieure.
- Pl. LVIII. — A, B, C, D, chapiteau d'ante : A, fragment d'angle de la moulure : a, face antérieure; b, face inférieure; B, fragment de l'ante : a, face antérieure; b, face inférieure; C, fragment de la moulure : a, face antérieure; b, face inférieure; D, coupe; E, architrave de l'opisthodomé : a, face antérieure; b, face latérale; c, face supérieure.
- Pl. LIX. — A, bloc de la frise de l'opisthodomé : a, face antérieure; b, face latérale; c, face supérieure; B, bloc de la frise du pronaos : a, face antérieure; b, face latérale; c, face supérieure.
- Pl. LX. — Blocs et coupe du toichobate : A, bloc de l'assise inférieure du toichobate (sous le mur du pronaos) : a, face supérieure; b, face vers le pronaos; c, face latérale; B, coupe du toichobate; C, bloc de l'assise supérieure du toichobate (rangée vers le pronaos) : a, face supérieure; b, face antérieure; c, coupe.
- Pl. LXI. — A, bloc de l'assise inférieure du toichobate (au-dessous de l'ante) : a, face supérieure; b, face vers le péristyle (petit côté); c, face vers le péristyle (long côté); d, face vers le pronaos; B, plan des assises au-dessous de l'ante.

TABLE DES PLANCHES

- PL. LXII. — Blocs de l'assise inférieure du toichobate : A, bloc près de la porte latérale (?) : a, face supérieure ; b, face antérieure ; B, bloc vers la cella, avec trace de demi-colonne : a, face supérieure ; b, face latérale.
- PL. LXIII. — A, B, C, blocs de l'assise supérieure du toichobate, sous le jambage de la porte principale : Aa, face supérieure ; b, face vers le pronaos ; c, face latérale droite ; Ba, face supérieure ; b, coupe transversale ; c, coupe longitudinale ; C, fragment de l'autre côté de la porte, avec trou pour le gond ; D, plan de la porte principale.
- PL. LXIV. — Bloc de l'assise supérieure du toichobate (base intérieure du mur de la cella, entre les colonnes) : a, face antérieure ; b, face supérieure ; c, face latérale.
- PL. LXV. — Blocs de l'assise supérieure du toichobate (base intérieure des murs de refend) : A, face supérieure ; B, face latérale.
- PL. LXVI. — Bloc de l'orthostate : a, face antérieure ; b, face latérale ; c, face supérieure.
- PL. LXVII. — Blocs de l'orthostate : Aa, face contiguë au mur de refend ; b, face inférieure ; Ba, face antérieure ; b, face latérale ; c, face supérieure.
- PL. LXVIII. — Parpaing de l'ante : a, face antérieure ; b, face latérale vers l'extérieur ; c, face inférieure ; d, face supérieure.
- PL. LXIX. — Parpaings de l'ante : Aa, face latérale vers le pronaos ; b, face supérieure ; c, face inférieure ; Ba, face antérieure ; b, face latérale ; c, face supérieure.
- PL. LXX. — Parpaings contigus à l'ante : Aa, face extérieure ; b, face latérale gauche ; c, face latérale droite ; d, face supérieure ; e, face inférieure ; Ba, face latérale droite ; b, face inférieure.
- PL. LXXI. — Parpaings : Aa, face extérieure ; b, face latérale droite ; c, face supérieure ; B, bloc contigu à un mur de refend : a, face extérieure ; b, face latérale gauche ; c, face intérieure ; d, face supérieure.
- PL. LXXII. — Bloc du mur derrière l'architrave du pronaos : a, face extérieure ; b, face intérieure ; c, face latérale droite ; d, face supérieure.
- PL. LXXIII. — Parpaing avec harpe : a, face extérieure ; b, face intérieure ; c, face latérale droite ; d, face supérieure ; e, face inférieure.
- PL. LXXIV. — A, bloc d'angle de la base intérieure du mur de la cella (assise supérieure du toichobate) : a, face extérieure ; b, face supérieure ; B, reconstitution d'un angle rentrant ; C, fragment de l'assise supérieure du toichobate, sous une demi-colonne intérieure : a, face intérieure (vers le mur) ; b, face supérieure ; D, fragment de l'assise supérieure du toichobate, sous un pilastre intérieur : a, face extérieure ; b, face supérieure.
- PL. LXXV. — Fragments et reconstitution de la base de la demi-colonne intérieure et de l'assise du toichobate placée au-dessous.
- PL. LXXVI. — Reconstitution du chapiteau de l'ordre intérieur : a, vue de face ; b, vue de dessous ; c, coupe.
- PL. LXXVII. — Chapiteau du pilastre intérieur : a, face tournée vers la porte de la cella ; b, face tournée vers les demi-colonnes ; c, face supérieure ; d, plan.
- PL. LXXVIII. — Fragments de l'architrave de l'ordre intérieur : Aa, face antérieure ; b, face postérieure ; c, face latérale ; d, face inférieure ; Ba, face antérieure ; b, coupe montrant l'amorce de la frise ; C, face antérieure ; D, fragment avec partie inférieure de la frise : a, face antérieure ; b, coupe.
- PL. LXXIX. — Couronnement intérieur du mur de la cella : a, face antérieure ; b, face latérale ; c, face supérieure.
- PL. LXXX. — Bloc d'angle du couronnement intérieur du mur de la cella : a, face antérieure ; b, face latérale gauche ; c, face latérale droite ; d, face supérieure.
- PL. LXXXI. — La fontaine : A, coupe longitudinale ; B et C, coupes transversales : B montrant le côté Sud, C montrant le côté Nord.
- PL. LXXXII. — Le temple d'Aléa Athéna : A, vue prise de l'Est ; B, vue prise du Sud-Est.
- PL. LXXXIII. — Le temple d'Aléa Athéna : A, vue prise du Sud-Ouest ; B, vue de la rampe Nord, prise de l'Est.
- PL. LXXXIV. — Vues de l'intérieur du temple : A, fond de la cella avec fondation de la base des statues ; B, fondations postérieures avec restes de dallage dans la cella.
- PL. LXXXV. — A, vue de la fouille pendant les travaux ; B, chapiteau de l'ordre extérieur ; C, vue des fondations à l'angle Nord-Est ; D, bloc du couronnement intérieur du mur de la cella, face inférieure.

· TEMPLE · D'ALÉA · ATHÉNA · À · TÉGÉE · PLAN · DE · SITUATION ·

· MOGENS · CLEMMENSEN · DEL. ·
· D'APRÈS · LE · RELEVÉ · DE · M. · ZURÉNIOS ·

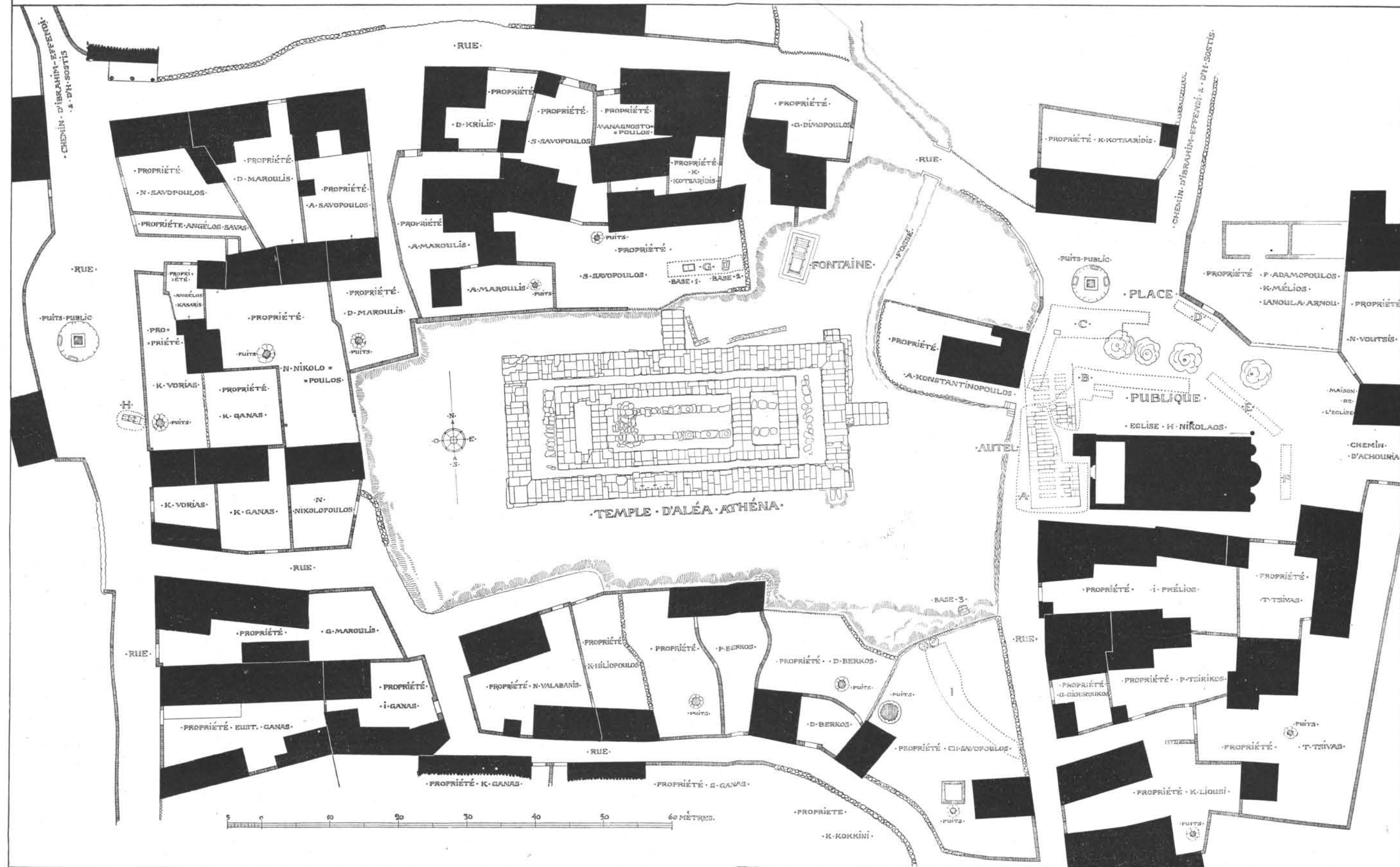

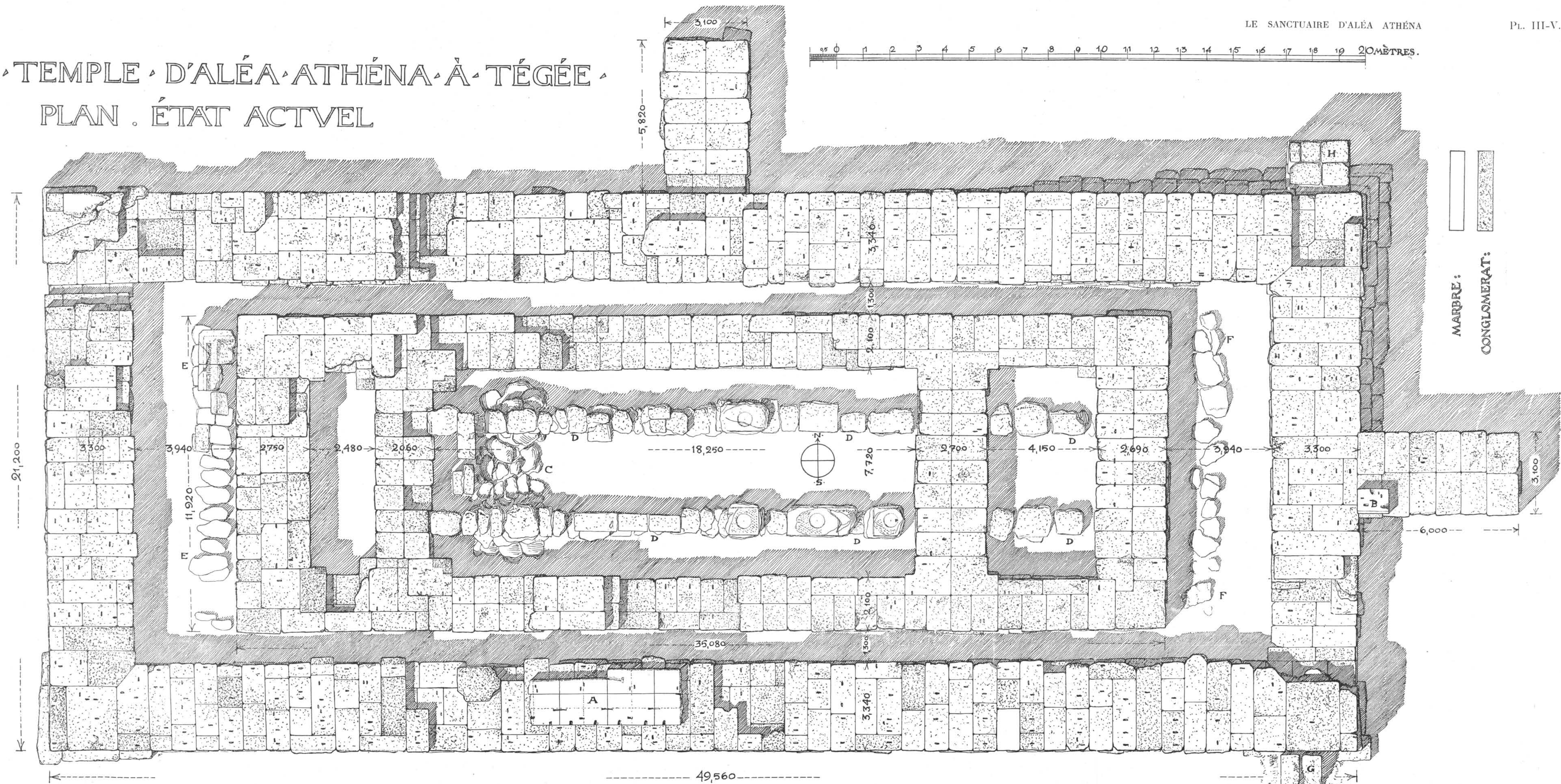
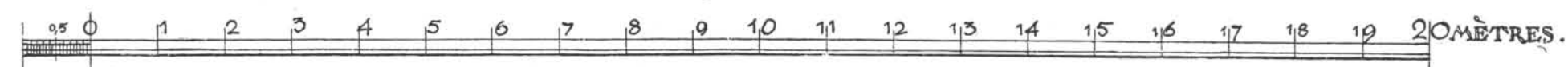

TEMPLE D'ALÉA ATHÉNA À TÉGÉE PLAN . ÉTAT ACTUEL



MARBRE:
CONGLOMERAT:

W. P. Wilson

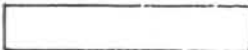
TEMPLE D'ALÉA ATHÉNA À TÉGÉE FONDATIONS

MARBRE : 
CONGLOMERAT : 

FAÇADE SUD

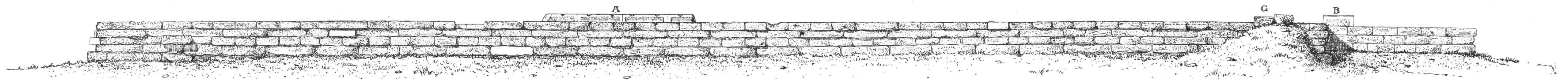

COUPE TRANSVERSALE

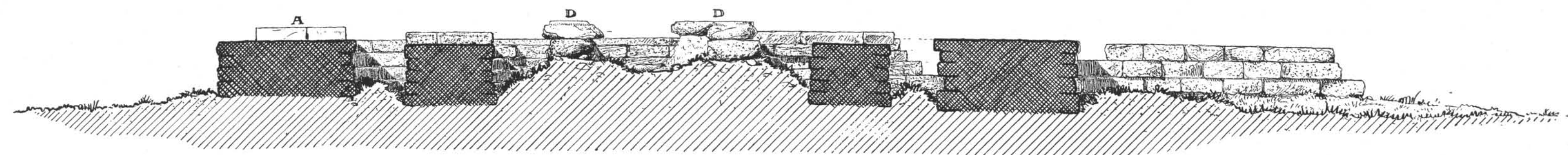

COUPE LONGITUDINALE

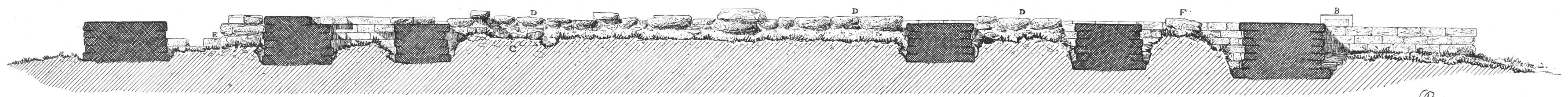

W. Perrot

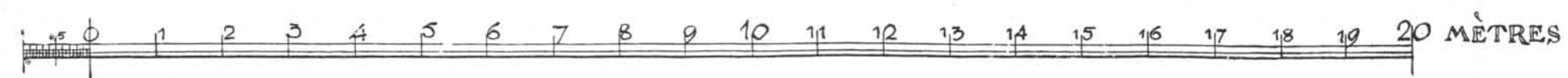

TEMPLE D'ALÉA ATHÉNA À TÉGÉE PLAN RESTAURÉ

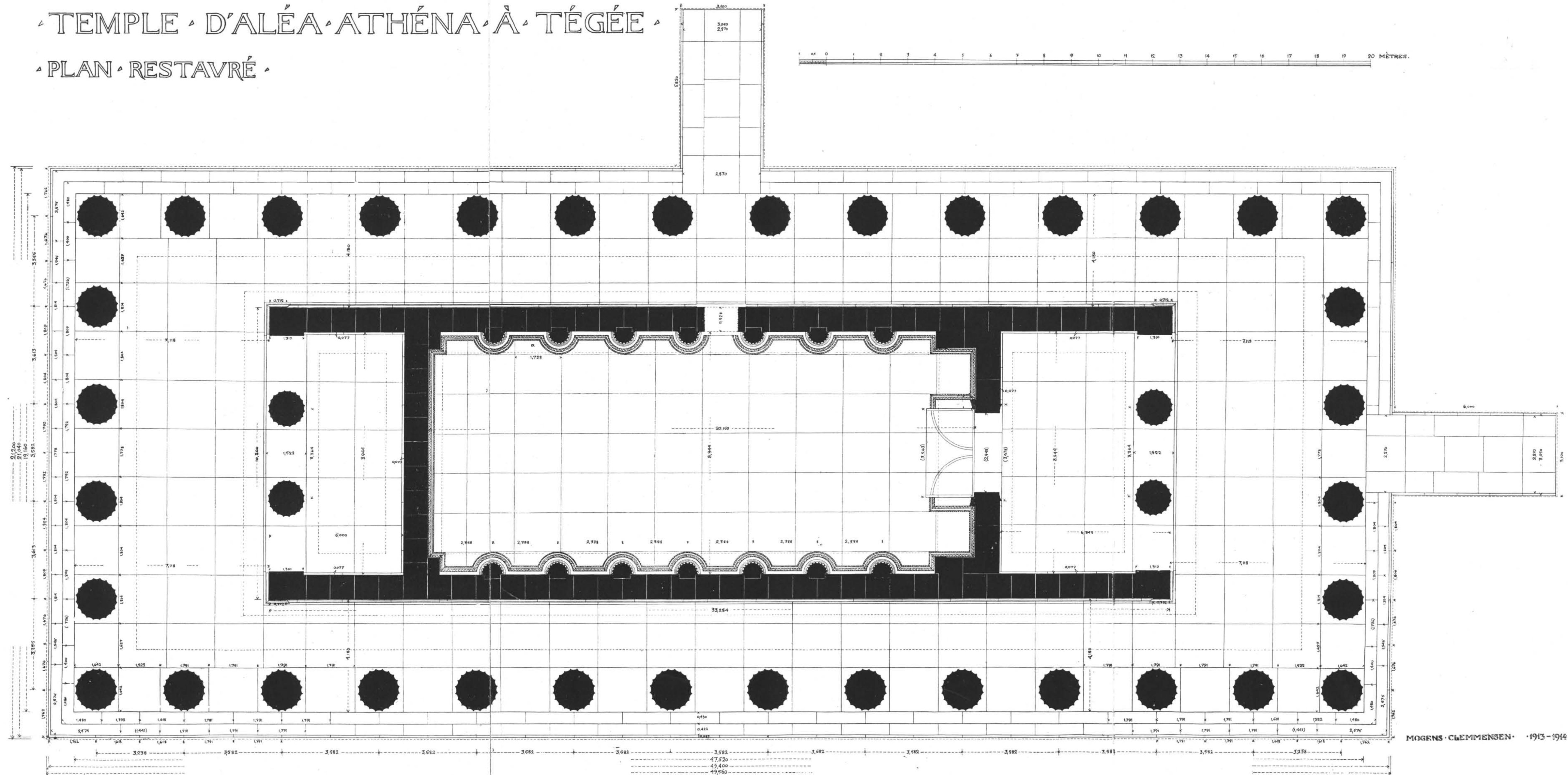
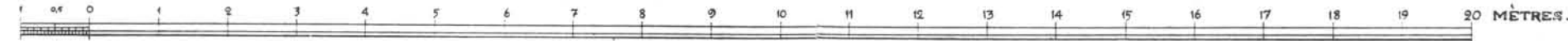

TEMPLE D'ALÉA ATHÉNA À TÉGÉE

LE SANCTUAIRE D'ALÉA ATHÉNA

PL. XII-XIV.

COVPE

FAÇADE EST

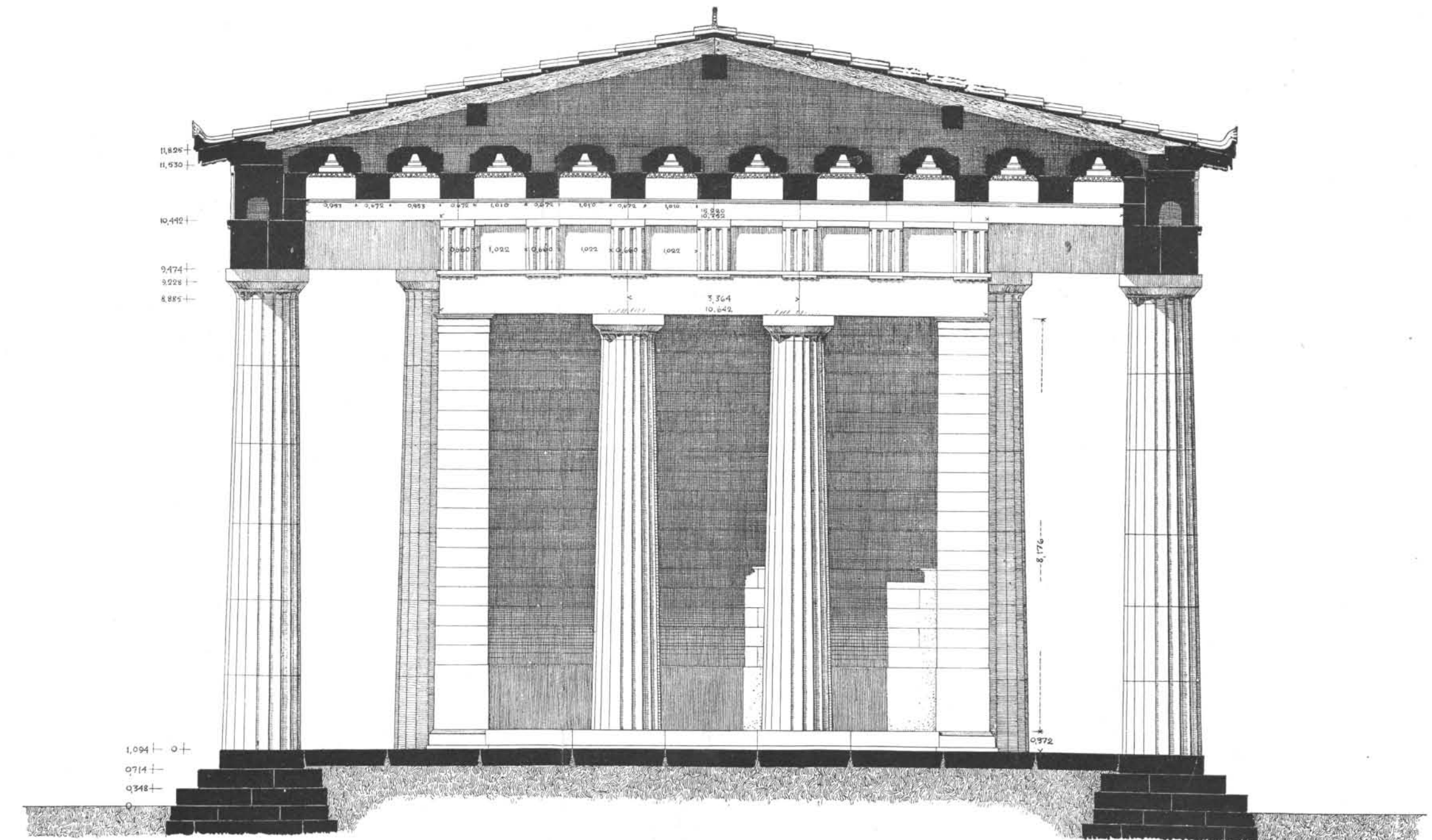
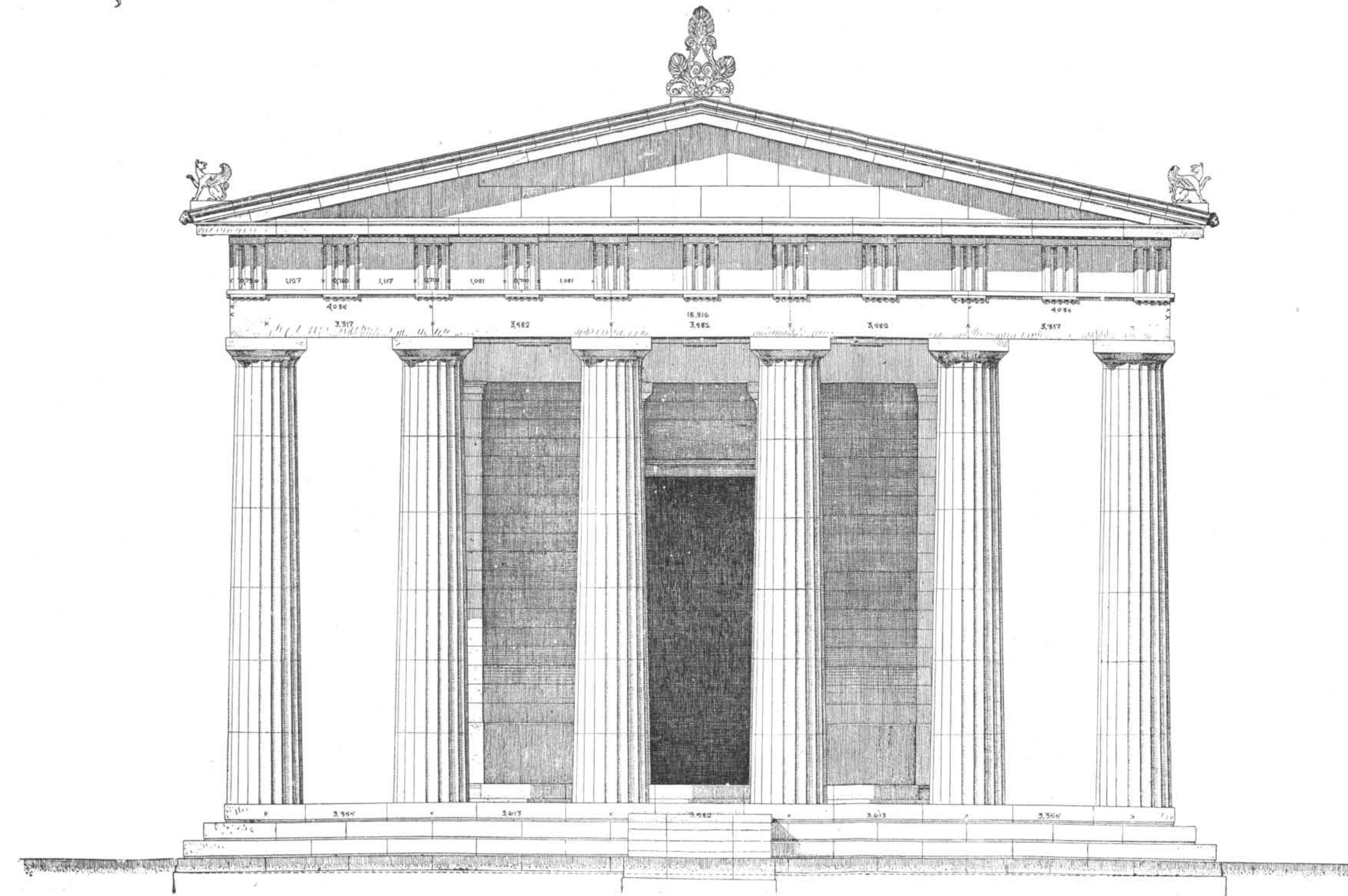

MOGENS · CLEMMENSEN ·
· 1913-1914 ·

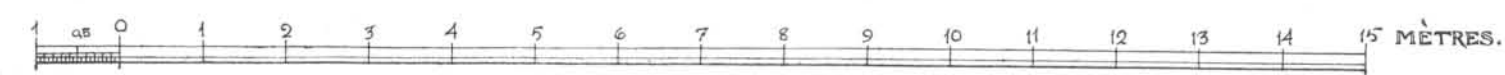

TEMPLE D'ALÉA ATHÉNA À TÉGÉE

LE SANCTUAIRE D'ALÉA ATHÉNA

PL. XV-XVII.

LONG CÔTÉ

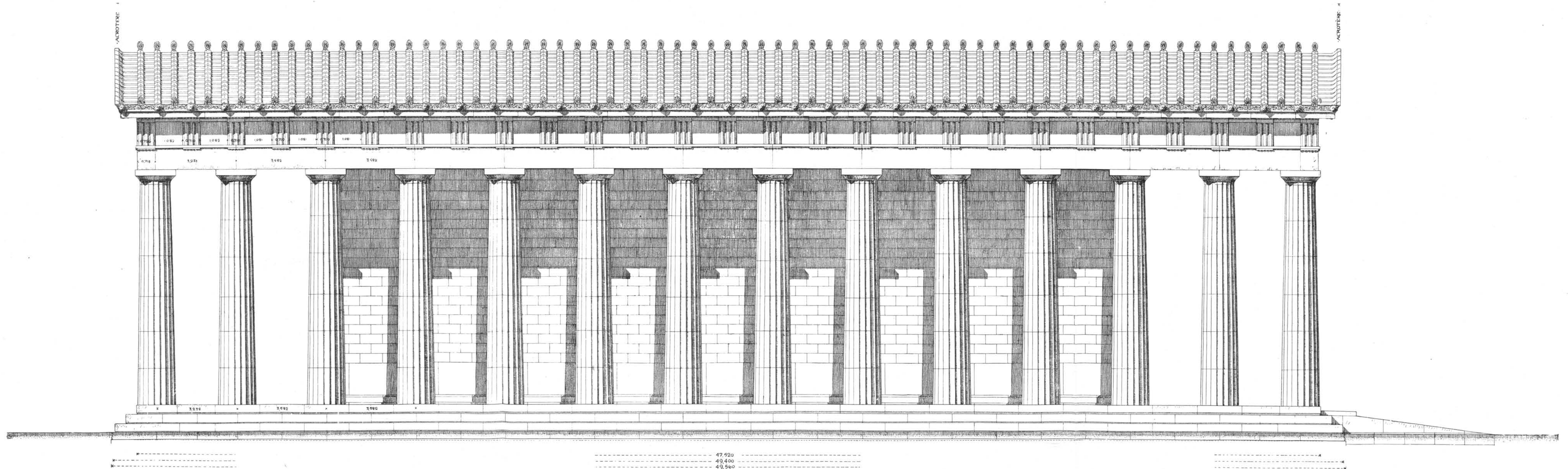

MOGENS CLEMMENSEN · 1913-1914 ·

TEMPLE D'ALÉA ATHÉNA À TÉGÉE

LE SANCTUAIRE D'ALÉA ATHÉNA

Pl. XVIII-XX

COUPE LONGITUDINALE

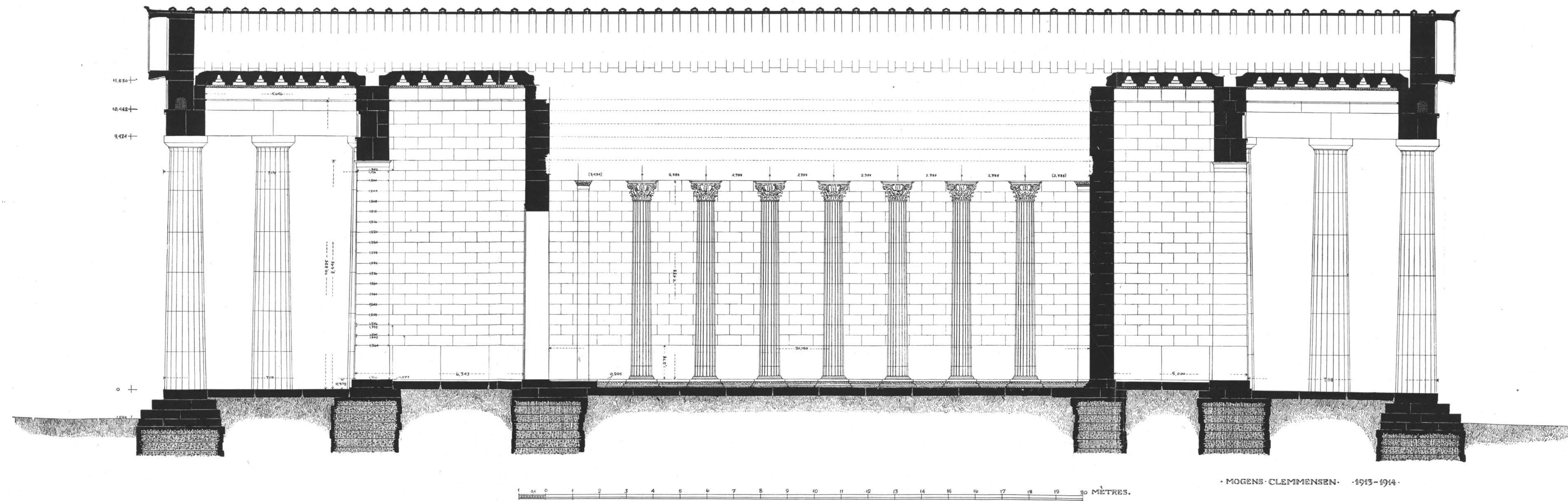

VERTICAL.

LE SANCTUAIRE D'ALPHA ATHENA

Pl. XXI-XXVI.

VERTICAL.

VERTICAL.

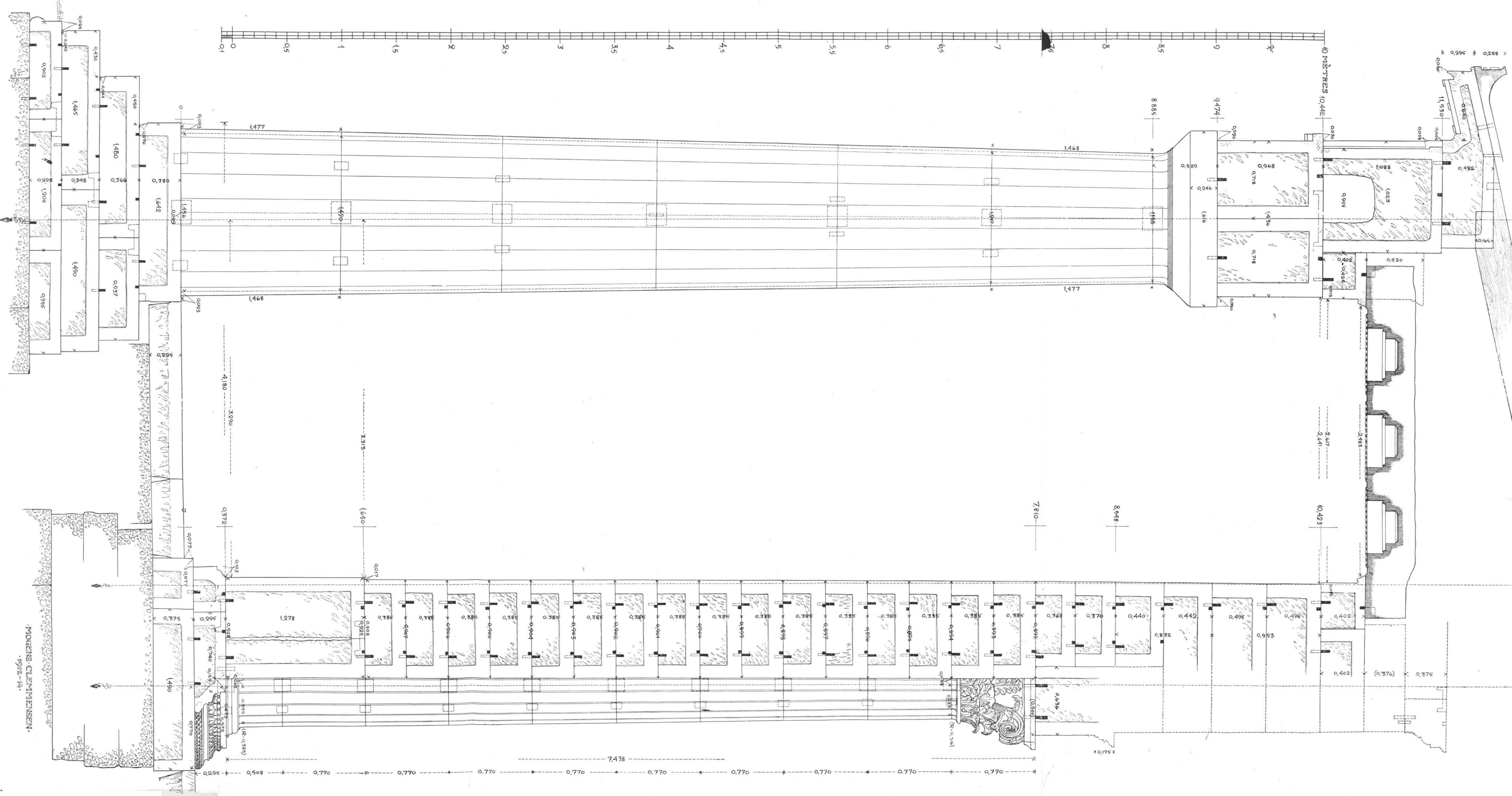

COUPE SUR LE PÉRISTILE.

MOEENS-CLEMENSSEN
1912-14.

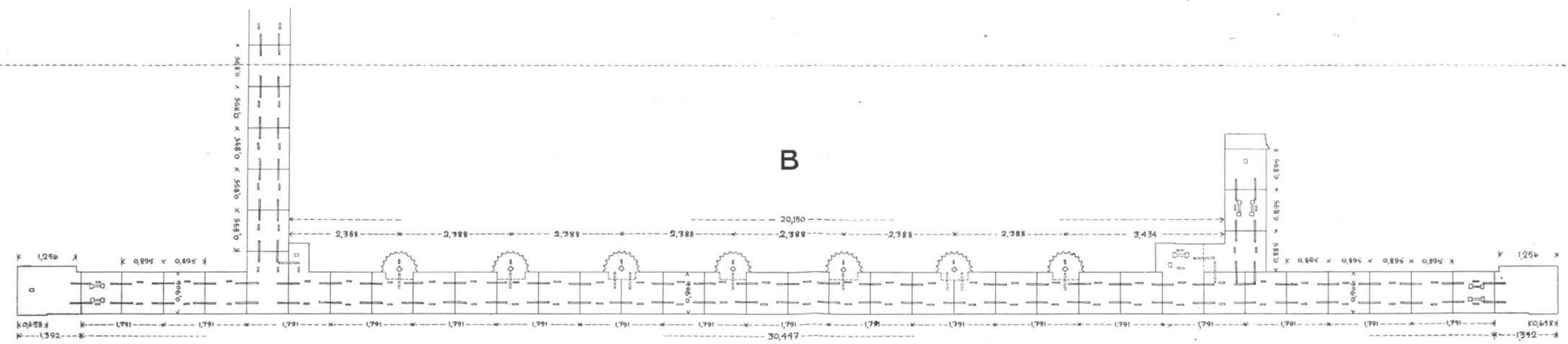
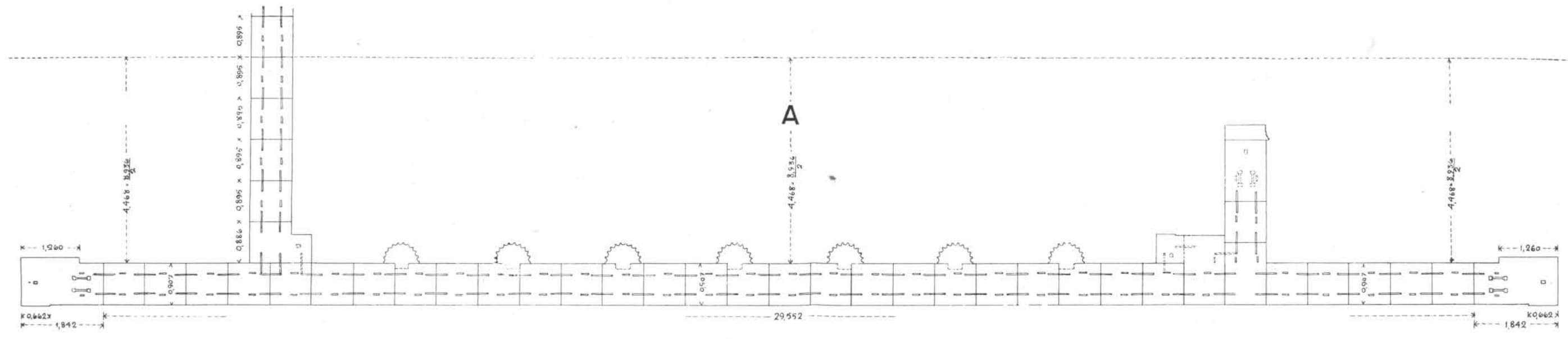

LES MURS DU TEMPLE (ASSISES SUPERPOSÉES).

M. Gr. 1915

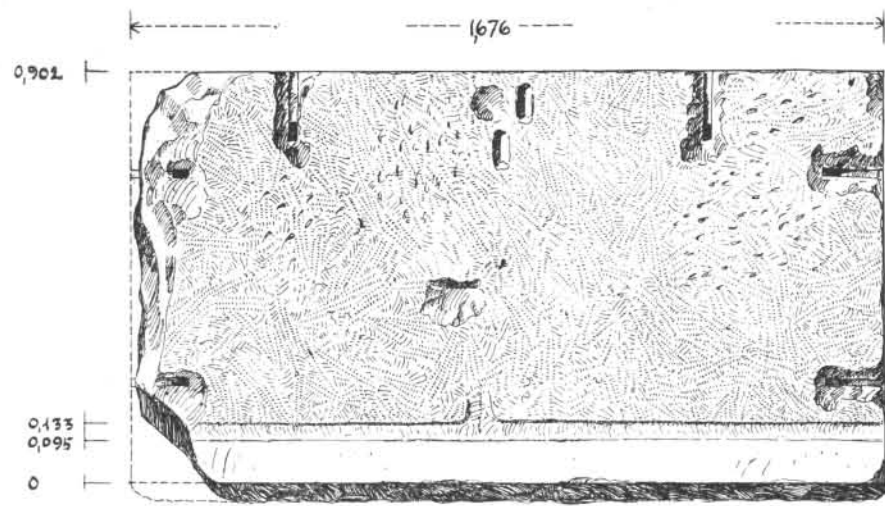

· Aa ·



· Ac ·

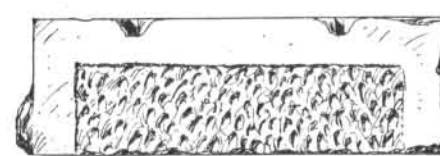

· Ac ·

m. Et. 1912.

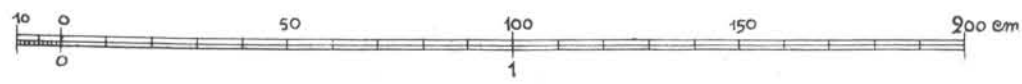

BLOCS DE L'EUTHINTÉRIA.

· A ·

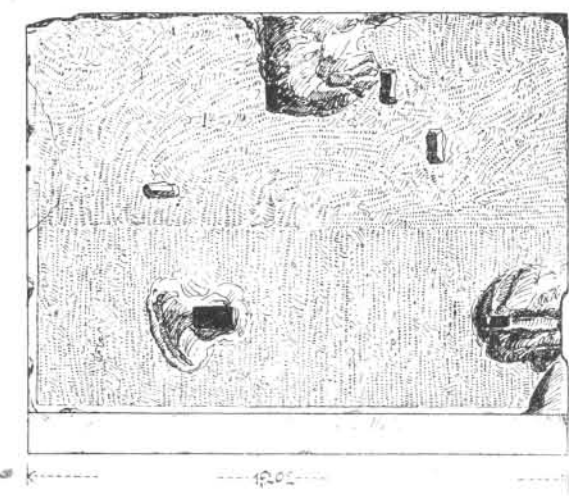

· Ba ·



· C ·

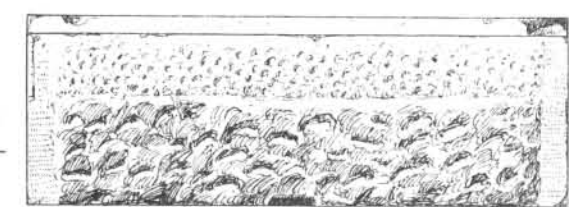

· Bb ·

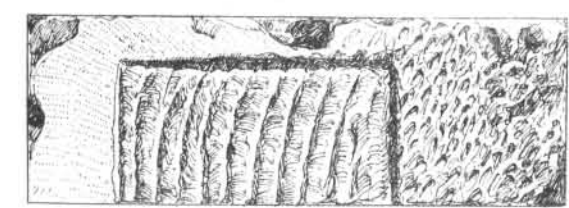

· Bc ·

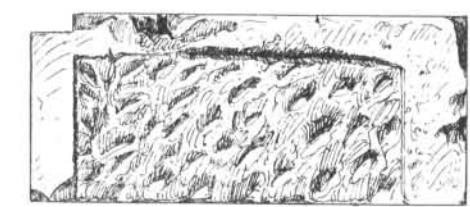

· Bd ·

m. Et. 1912.

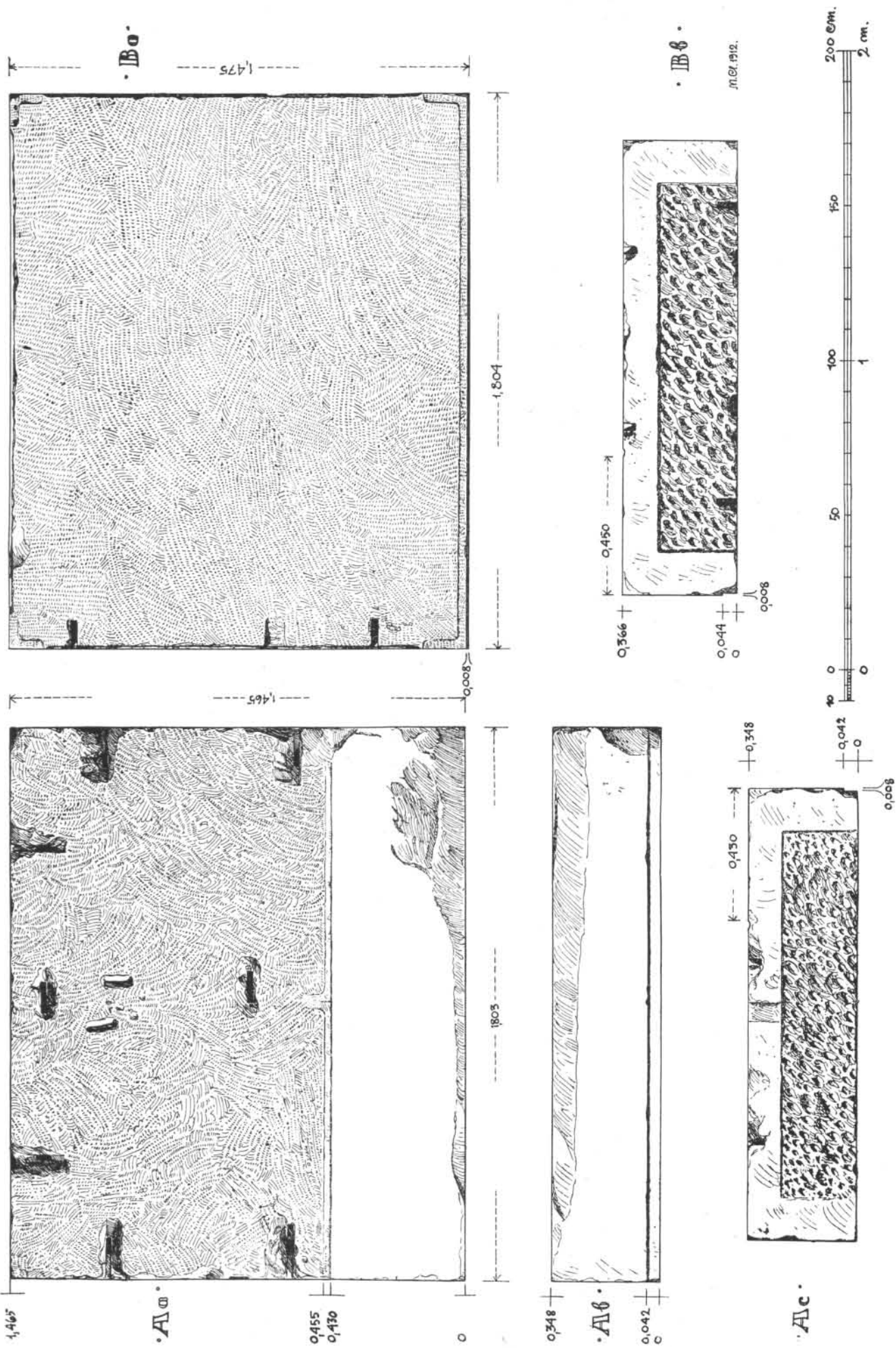

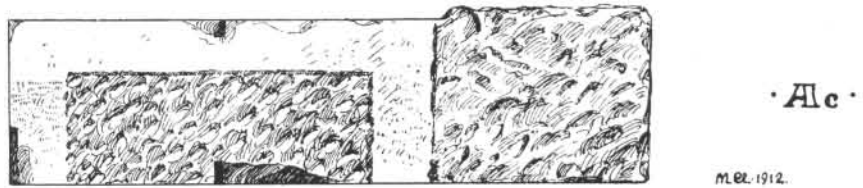
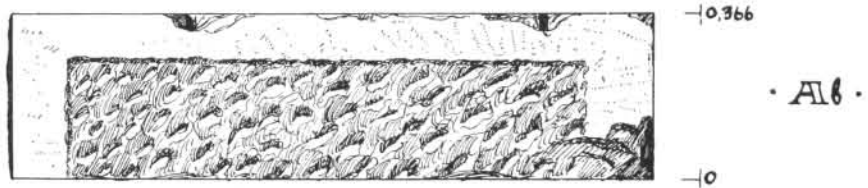
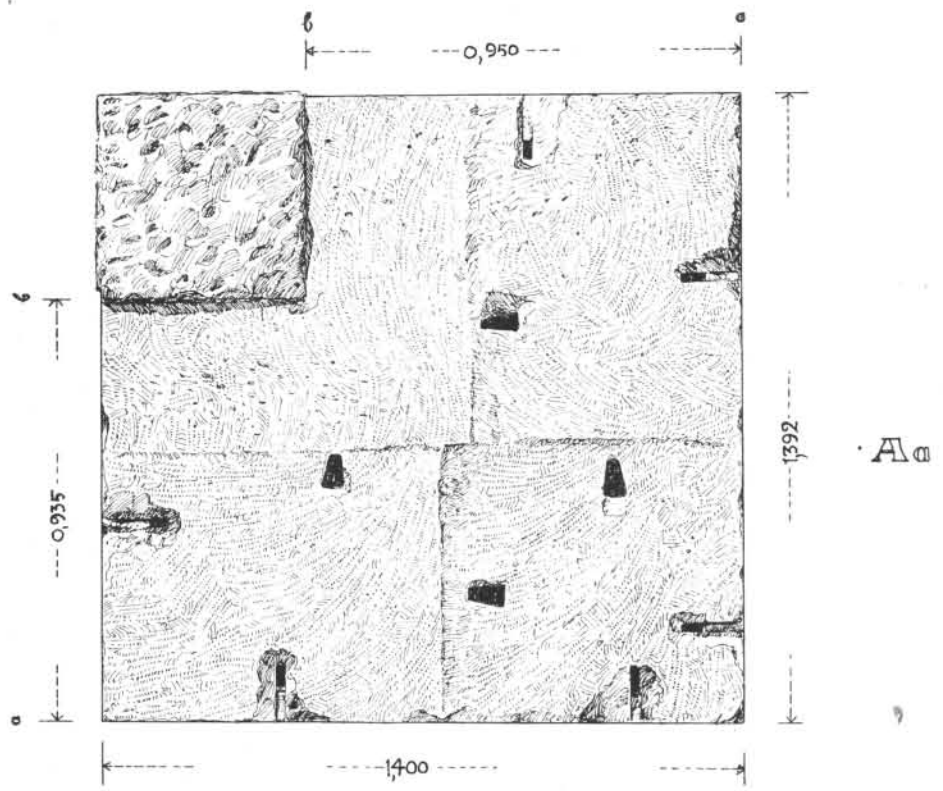

M. 1912.

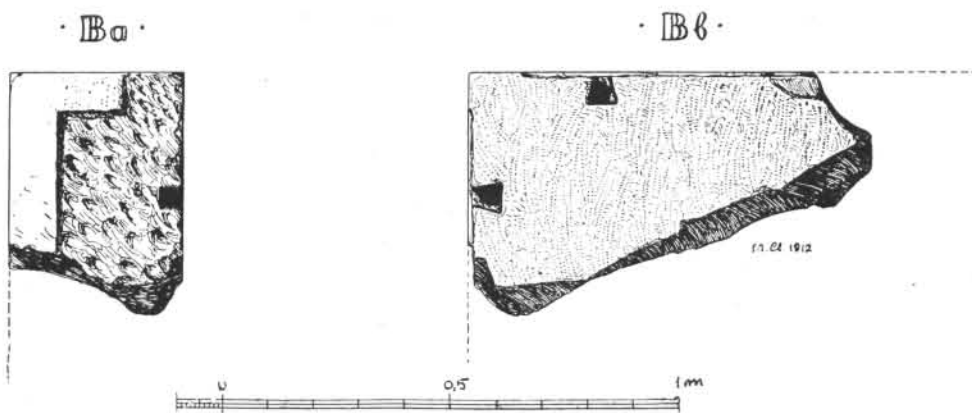

BLOCS DU SOUBASSEMENT.

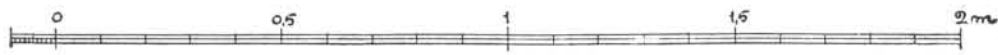
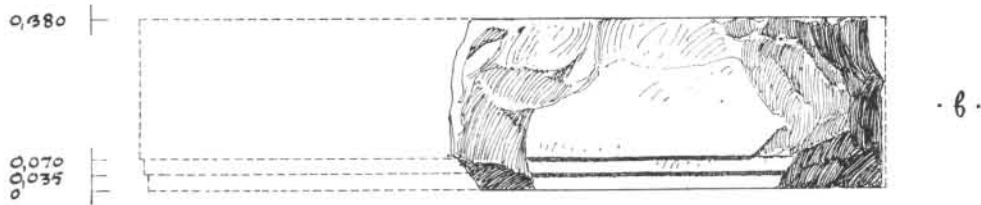
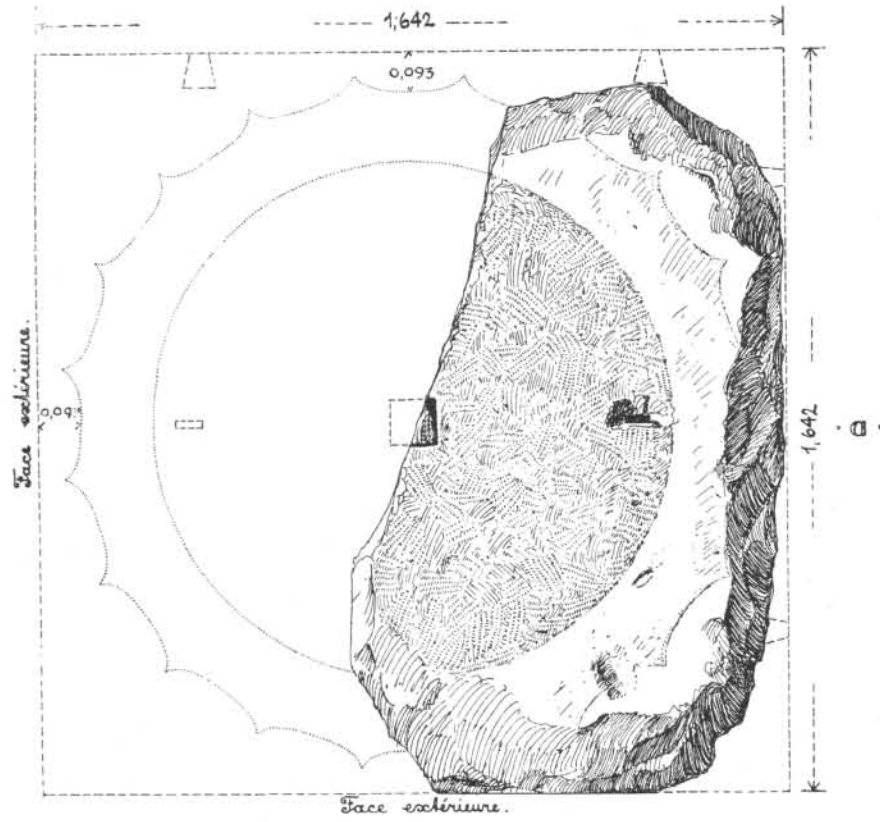

BLOC DU STYLOBATE.

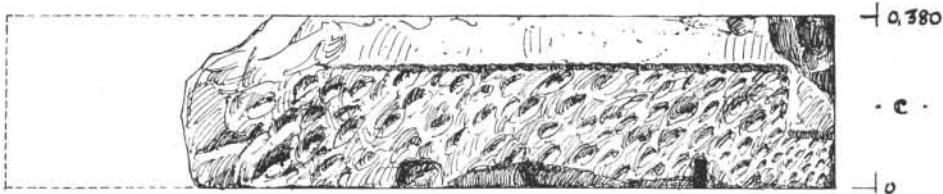
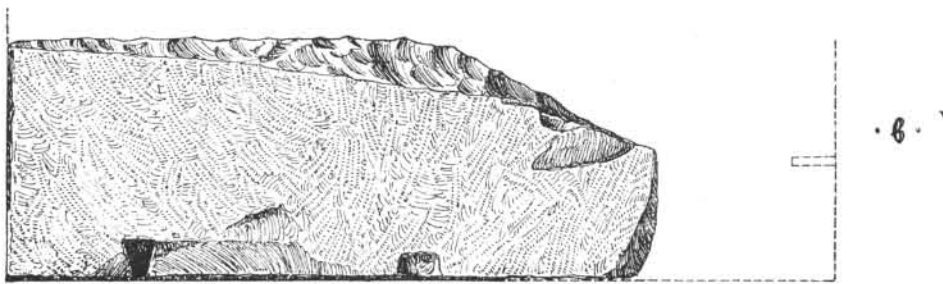
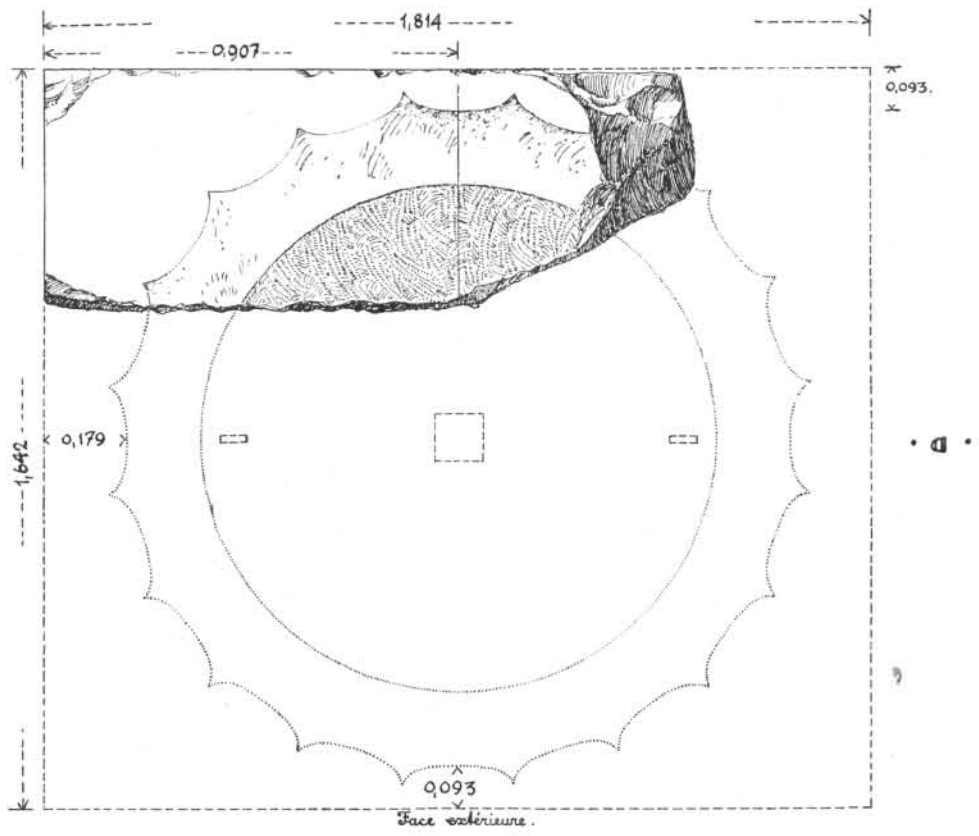

m. G. 1912.



BLOC DU STYLOBATE.

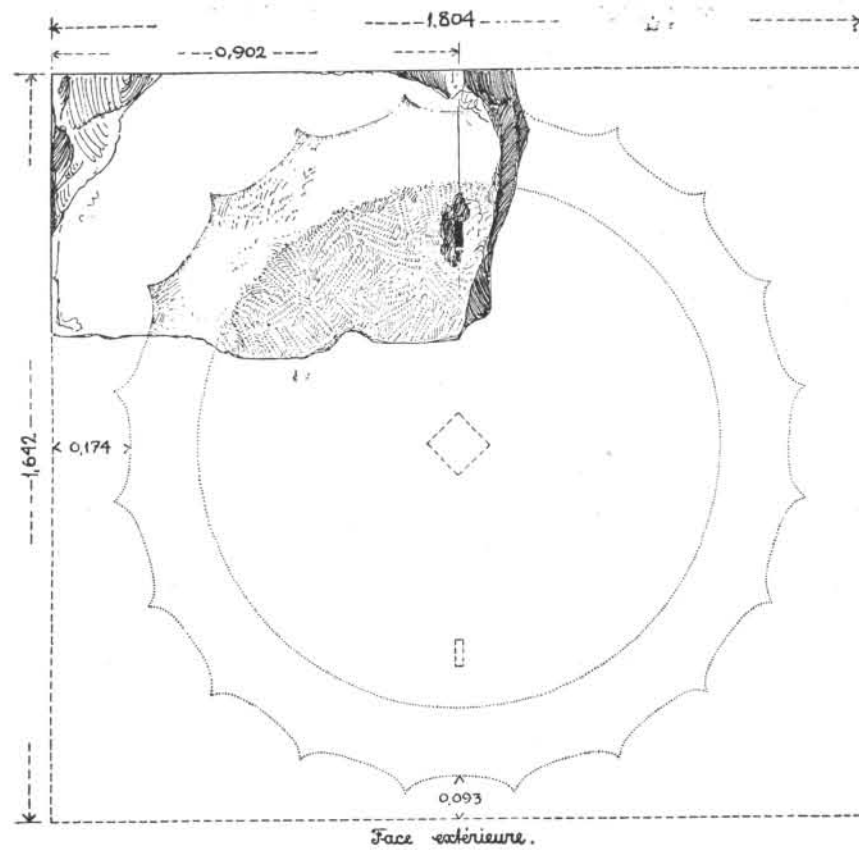

·Aa·

·GRAND DIAMÈTRE: 1,555.
·PETIT DIAMÈTRE: 1,456.

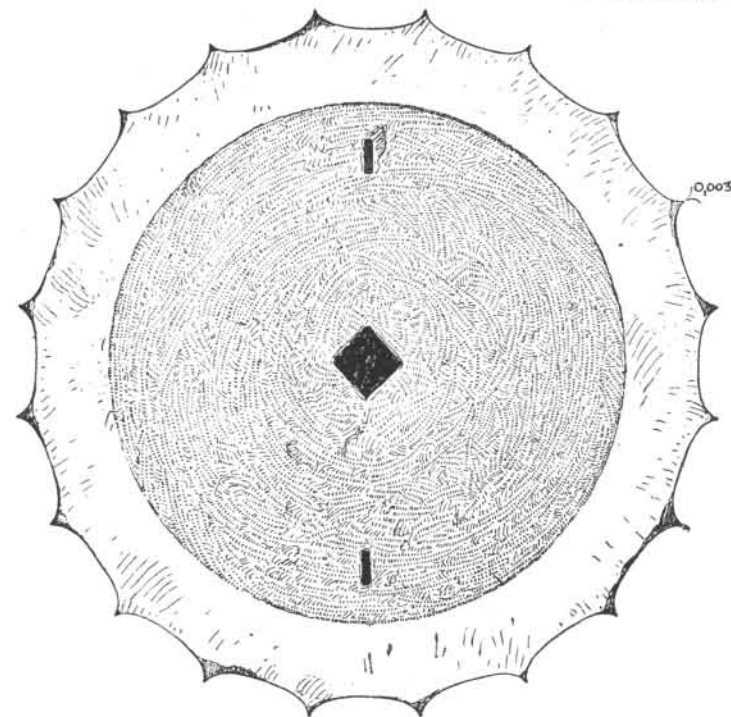

·Bb·

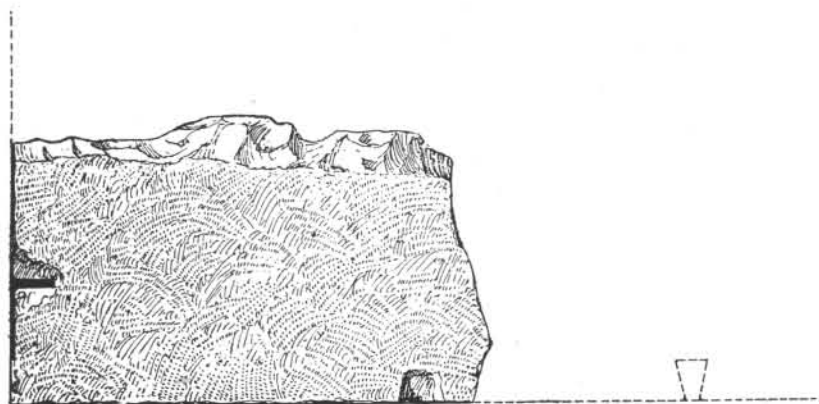

·Aa·

m. et. 1912.



BLOC DU STYLOBATE ET TAMBOUR DE COLONNE.

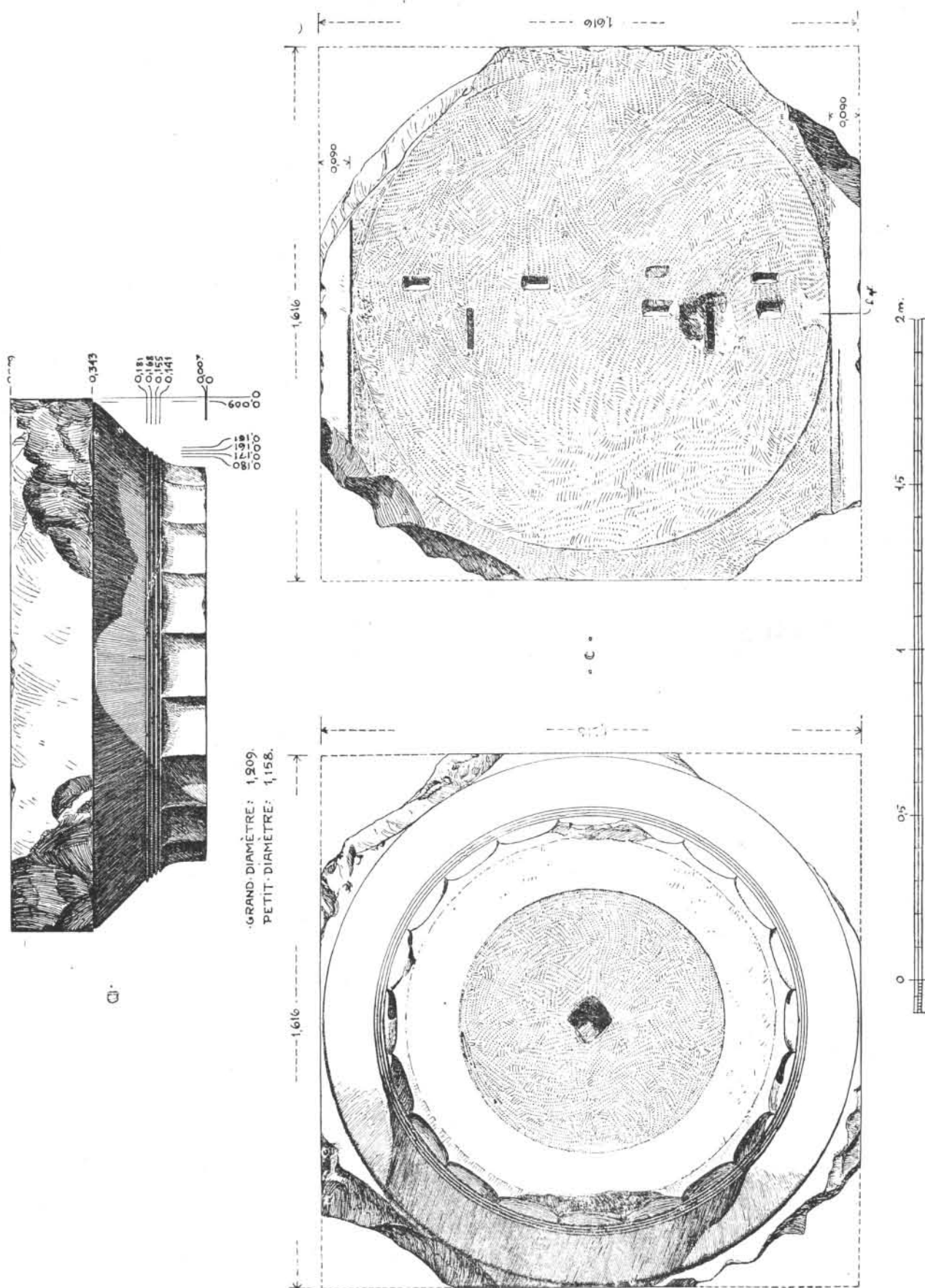

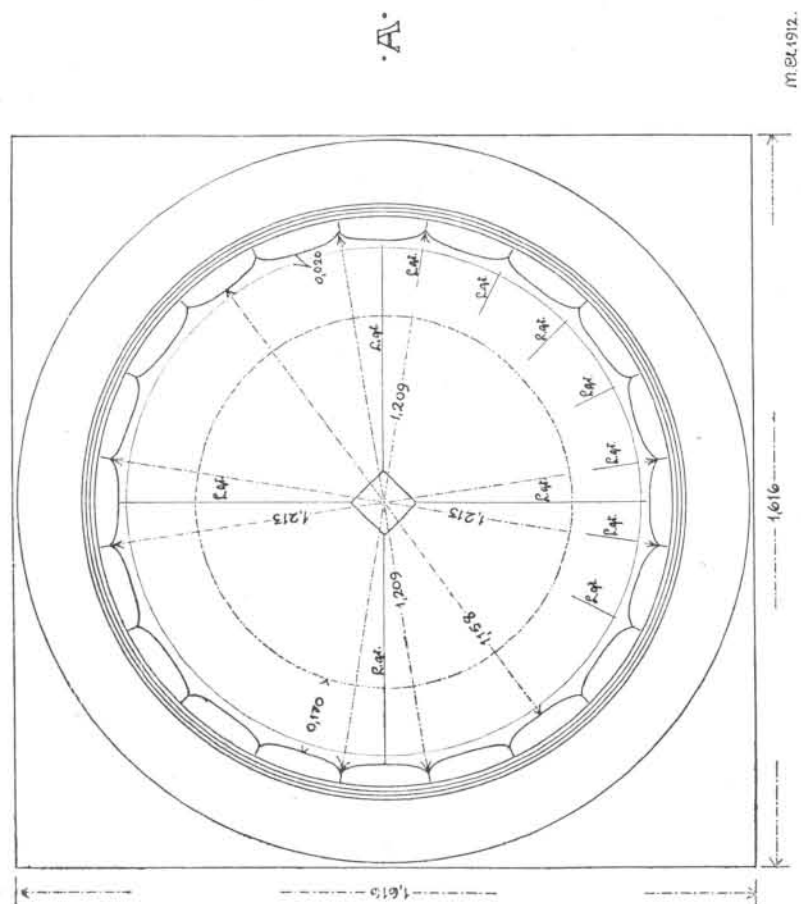
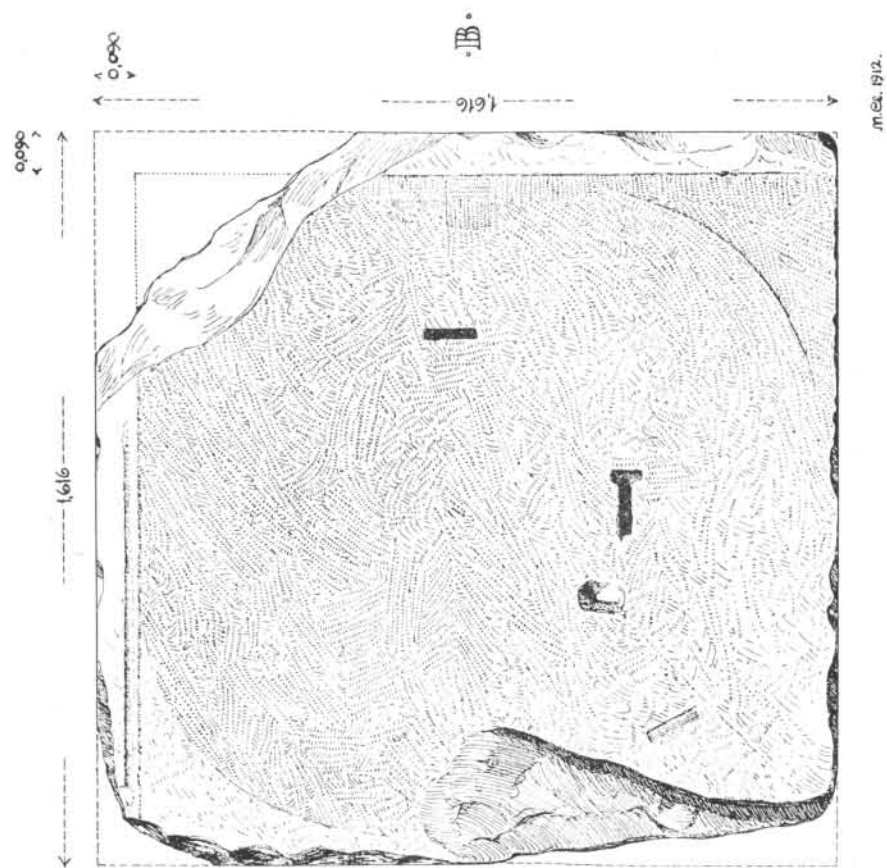

CHAPITEAUX DE L'ORDRE EXTÉRIEUR.

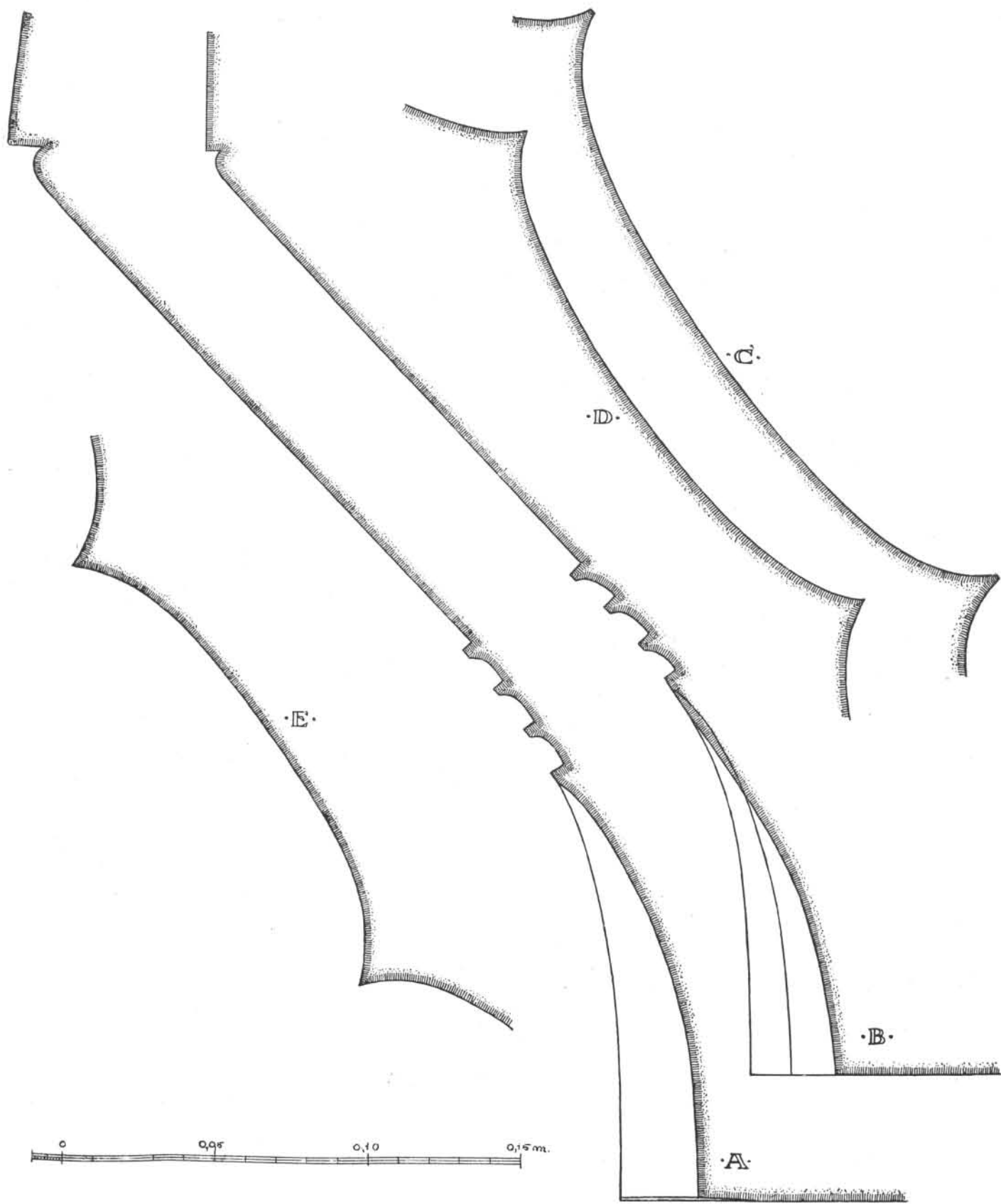

PROFILS DES CHAPITEAUX ET DES CANNELURES DES DEUX ORDRES DORIQUES.

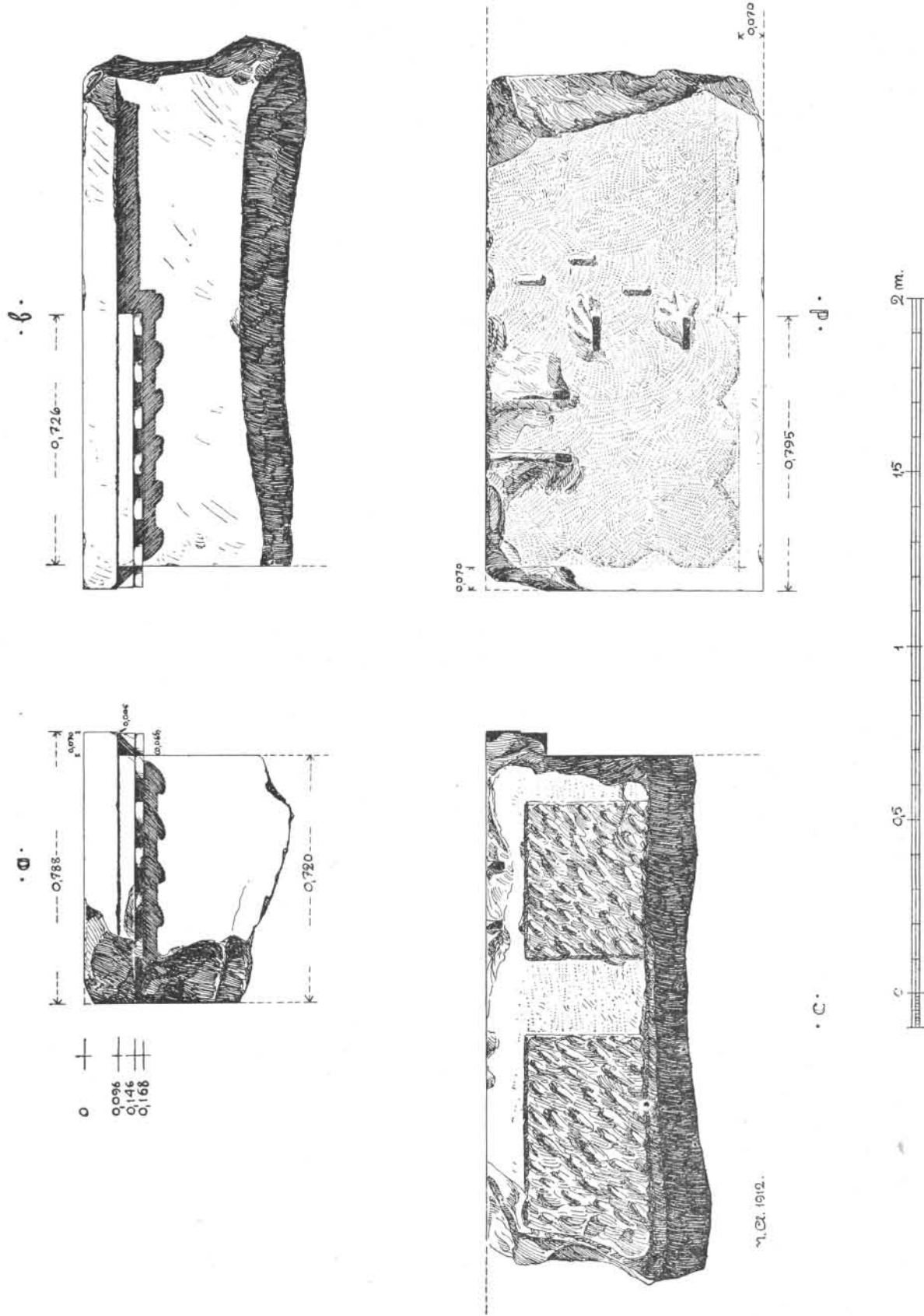

BLOC DE L'ARCHITRAVE DE L'ORDRE EXTÉRIEUR.

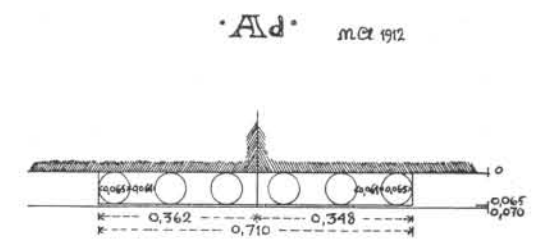
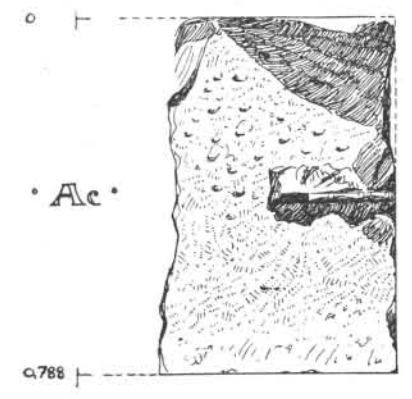
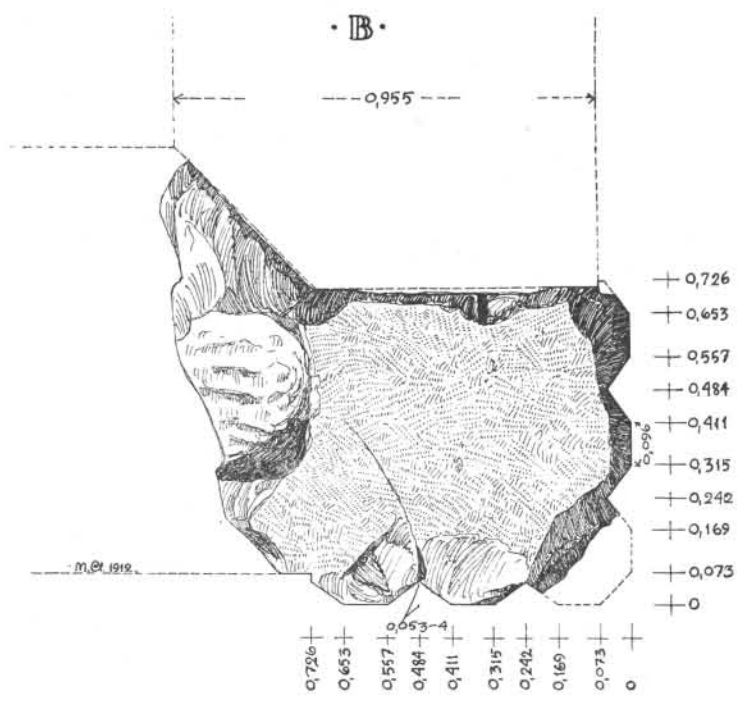
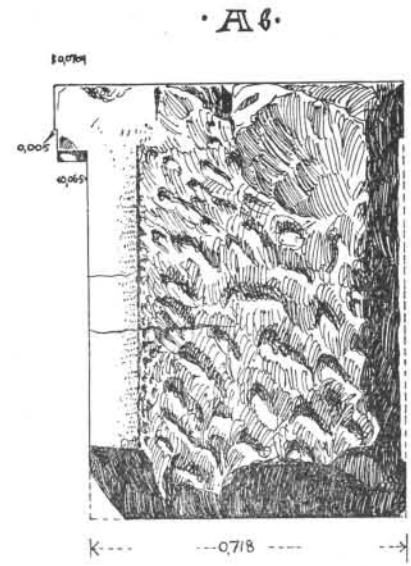
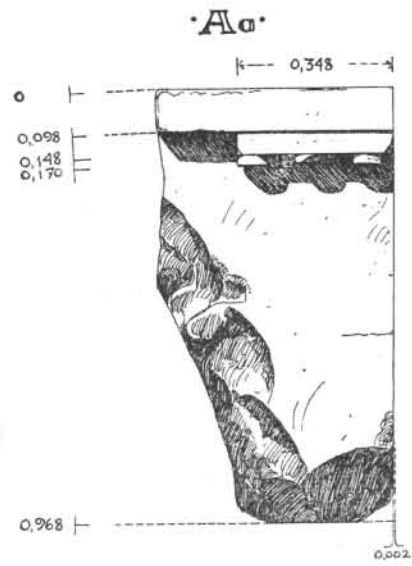

BLOCS DE L'ARCHITRAVE ET DE LA FRISE DE L'ORDRE EXTÉRIEUR.

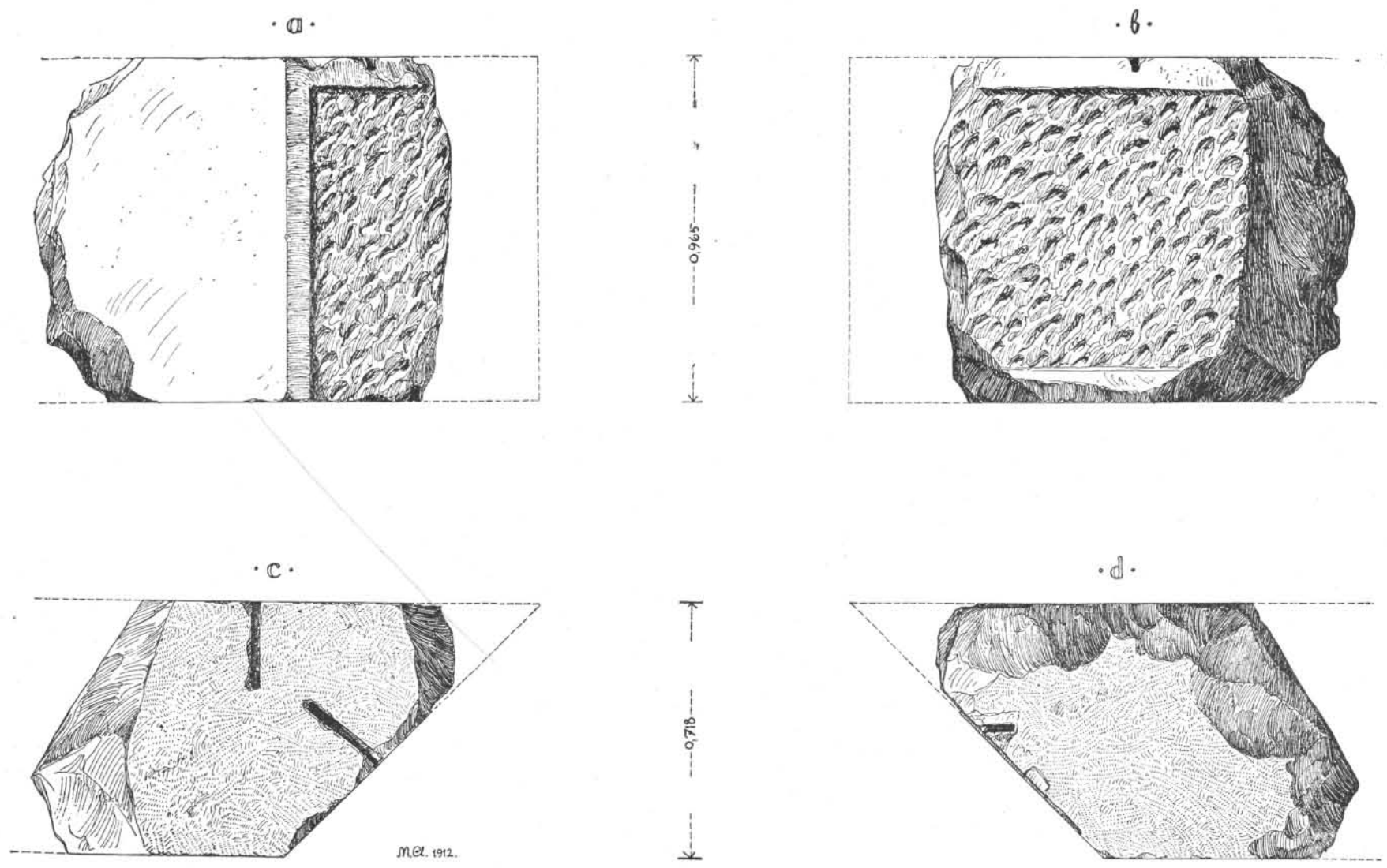

0 0,5 1 1,5 2 m

BLOC DE LA CONTRE-ARCHITRAVE.

M. G. 1912.

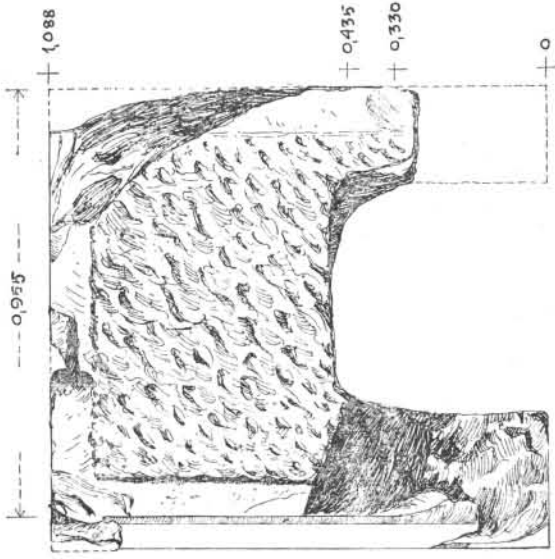

. B .

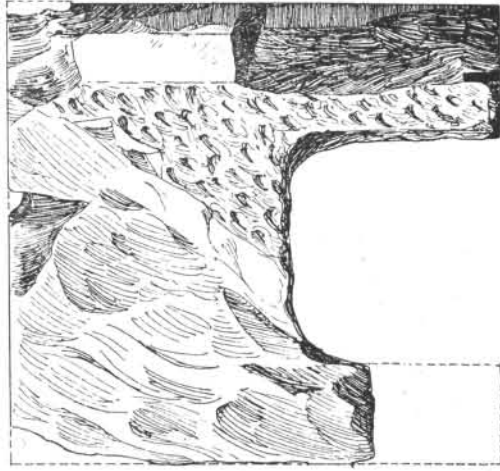

. C .

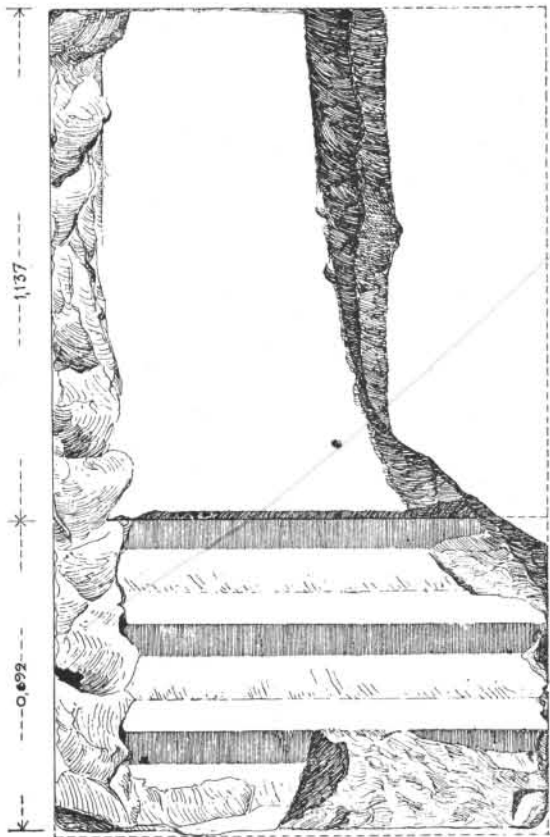

. D .

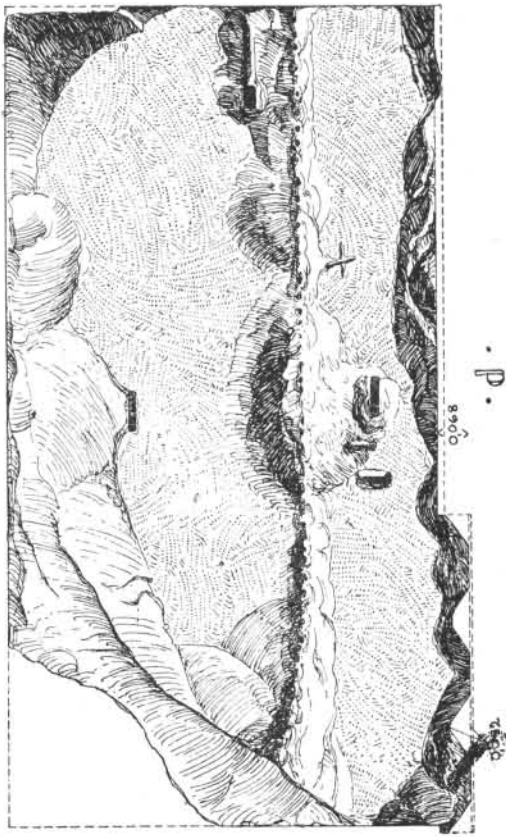

. D .

m. et 1912.

2 m.

1/5

1

0,5

0

BLOC DE LA FRISE DE L'ORDRE EXTÉRIEUR.

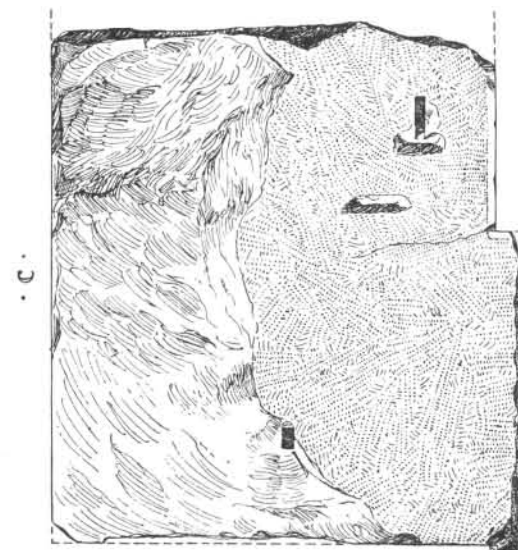
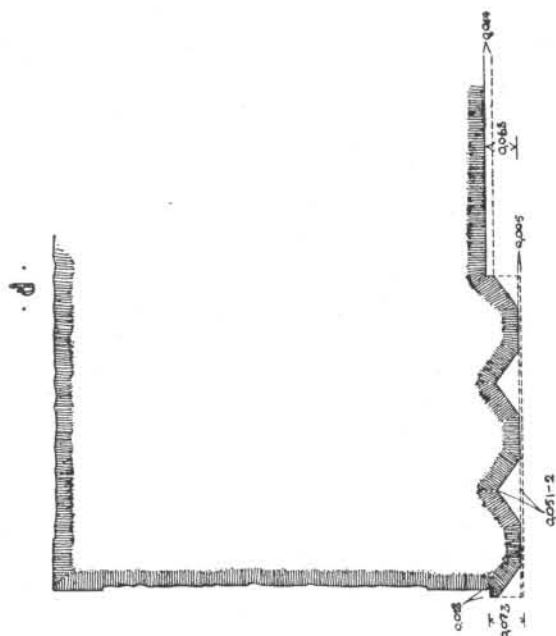
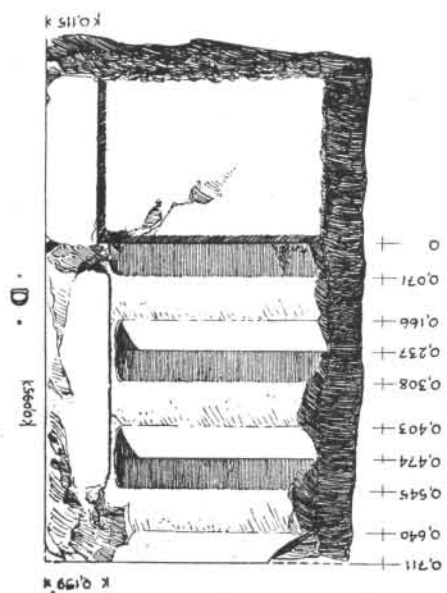
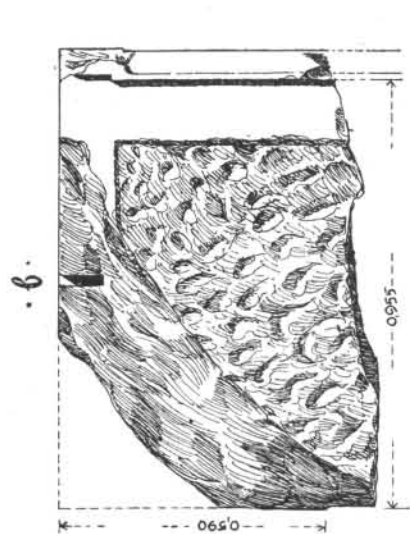

M. G. 1912.

1/5 m.

1

0.5

0

BLOC DE LA FRISE DE L'ORDRE EXTÉRIEUR.

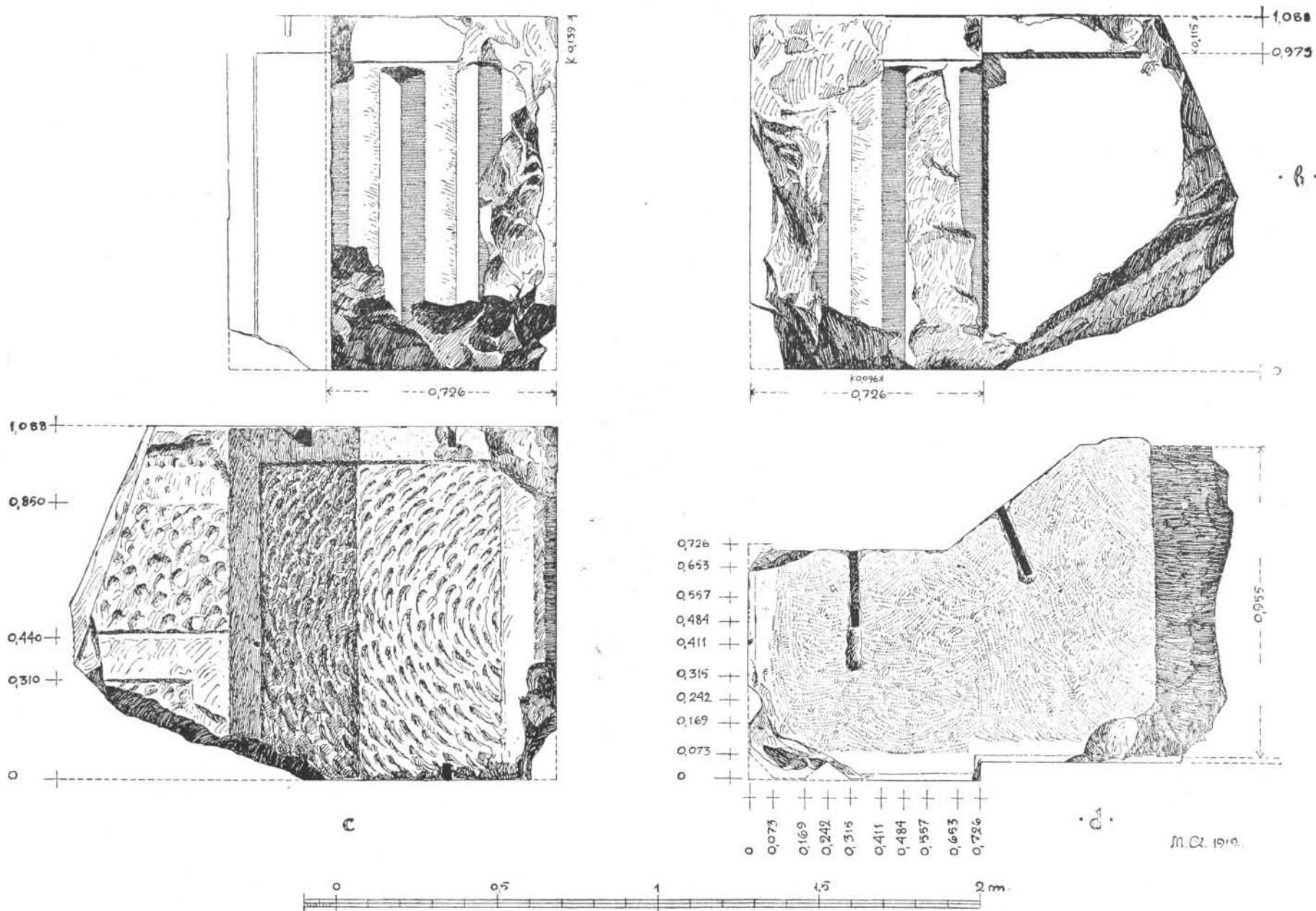

BLOC DE LA FRISE DE L'ORDRE EXTÉRIEUR.

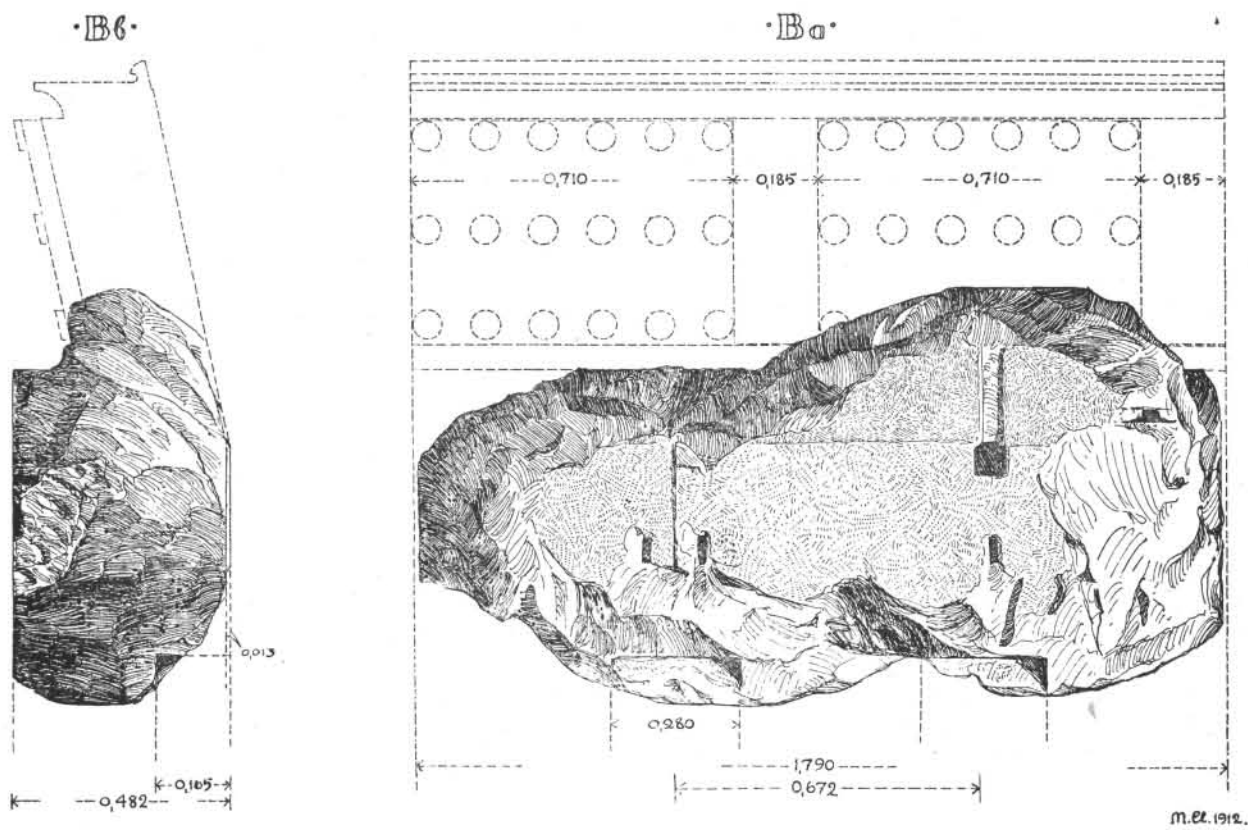
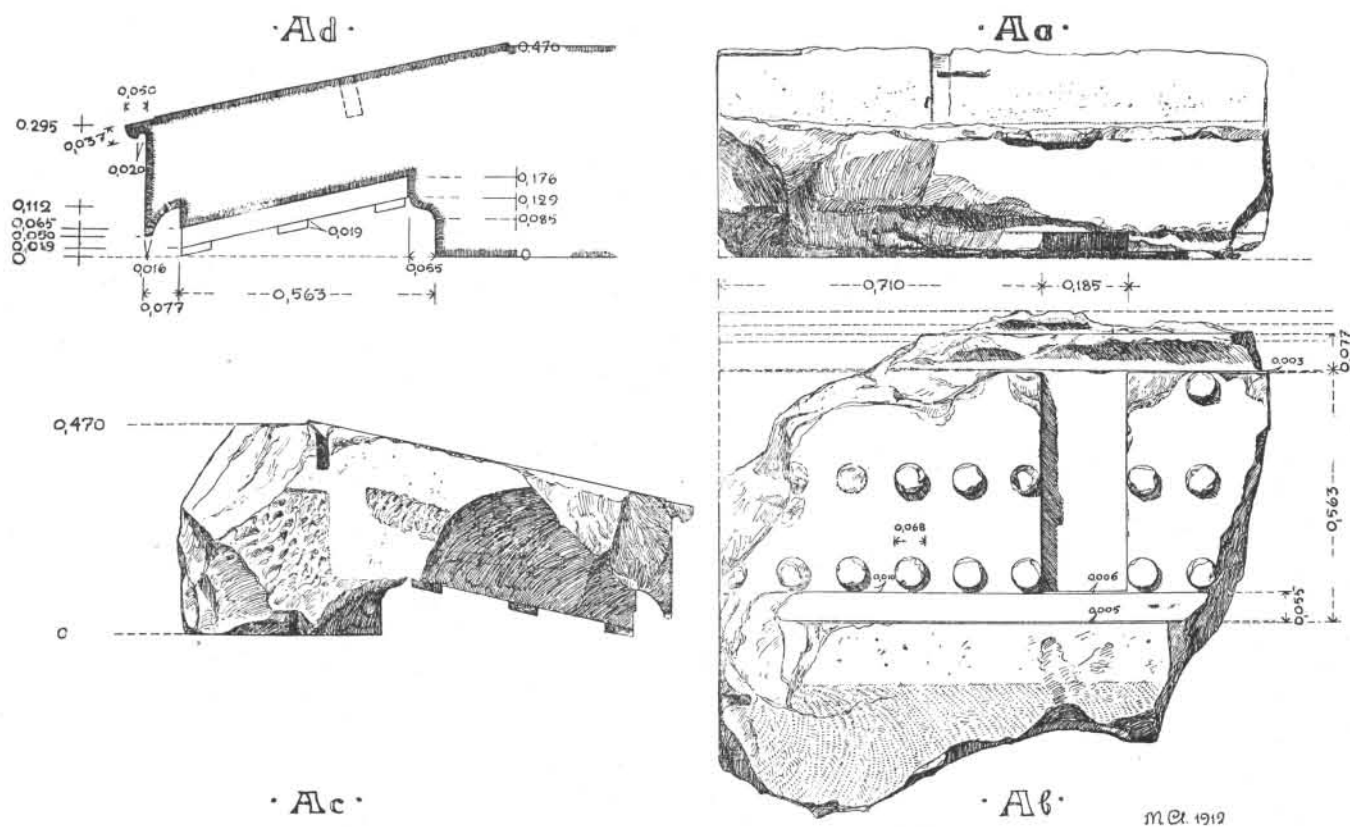

BLOCS DE LA CORNICHE DE L'ORDRE EXTÉRIEUR.

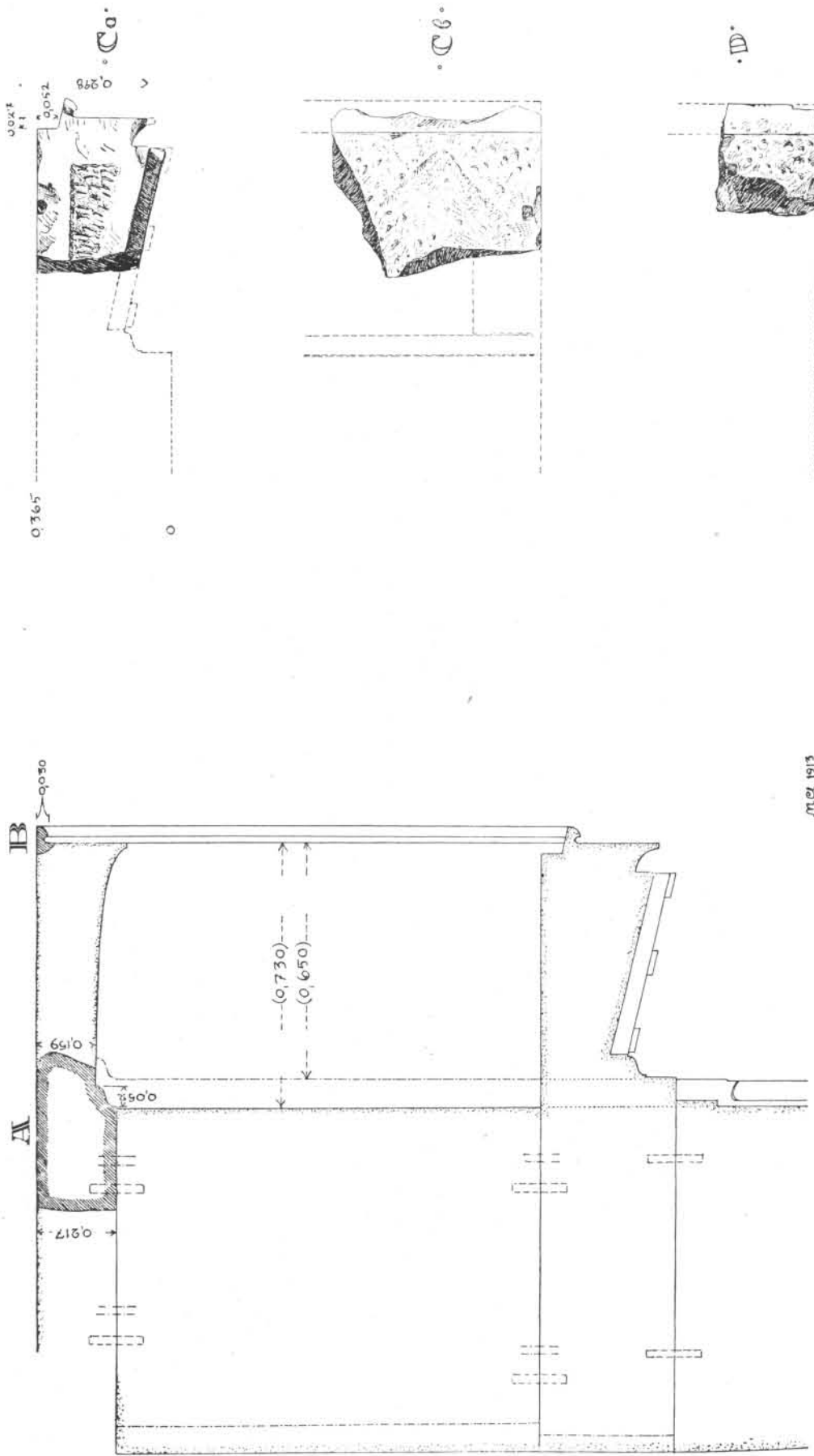

COUPE SUR LE FRONTON ET BLOCS DE LA CORNICHE.

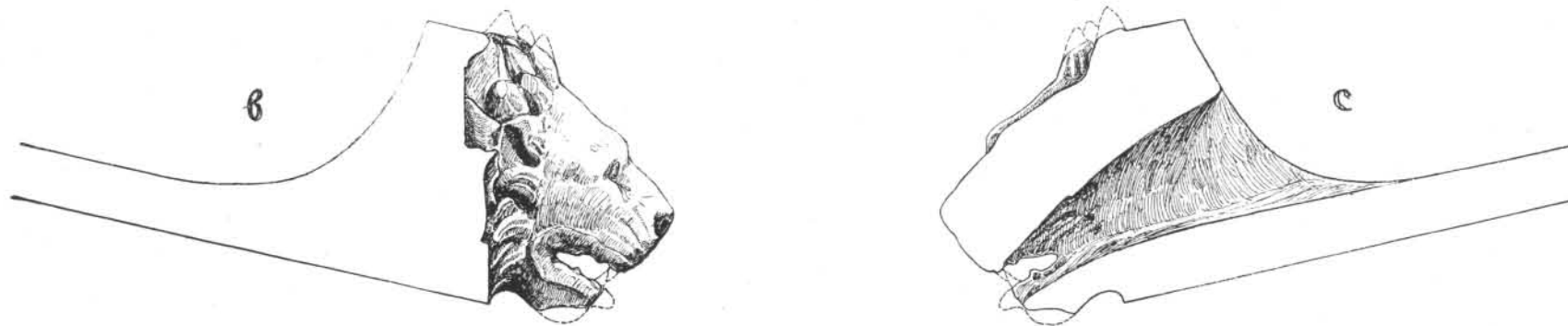
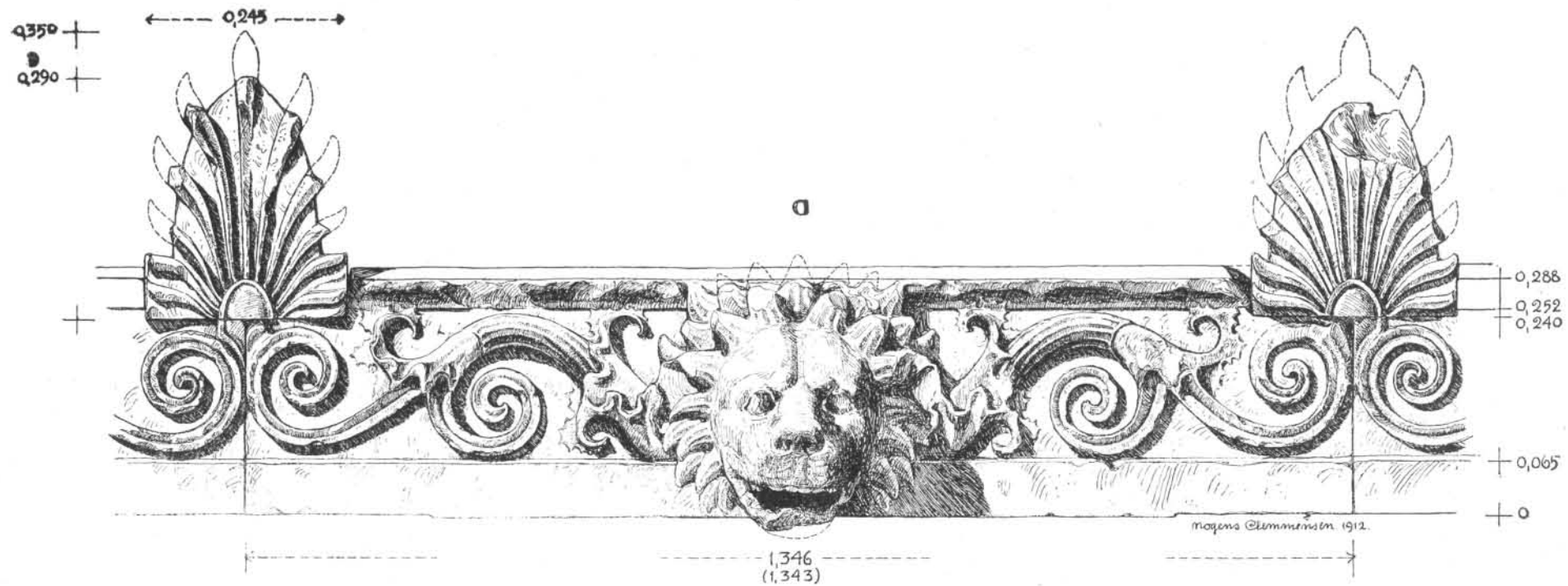

SIMA DES LONGS COTÉS.

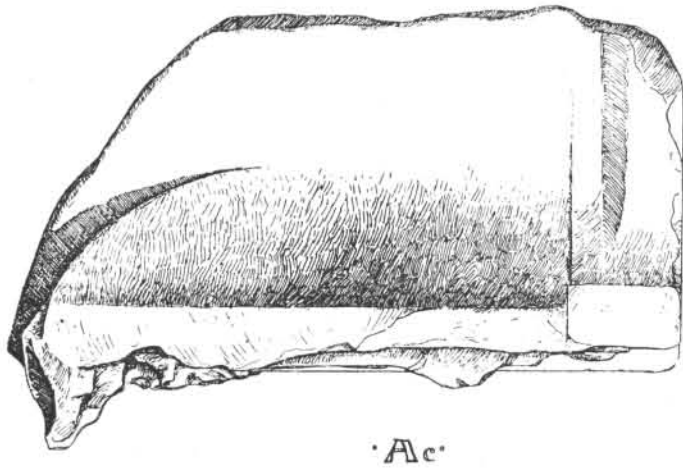
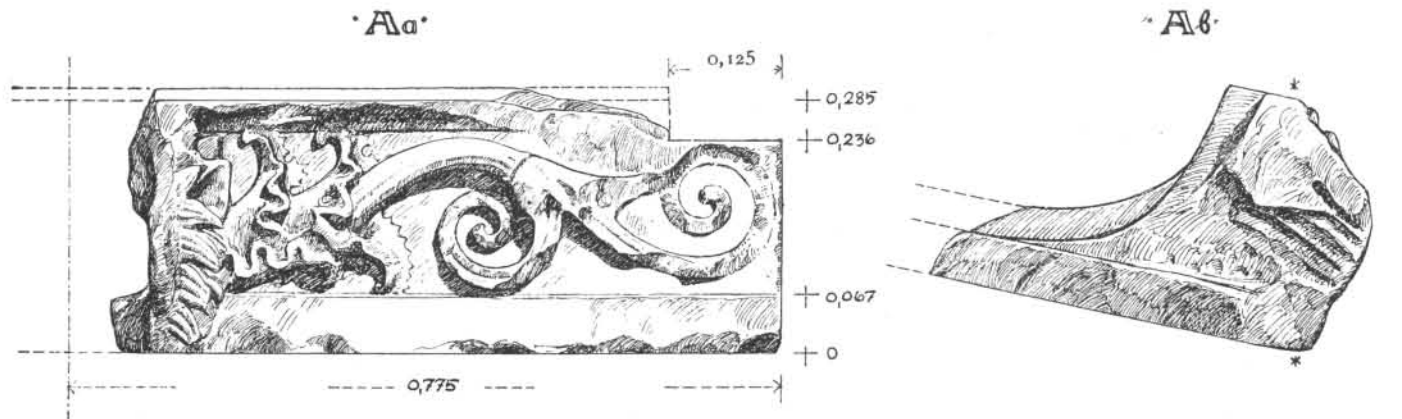

M. Et. 1912.



·Ba·

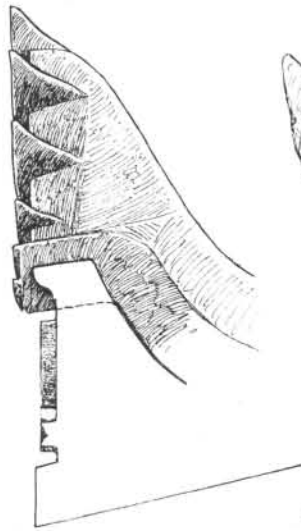

·Bb·



M. Et. 1912.

Ca



M. Et. 1912.

Cb

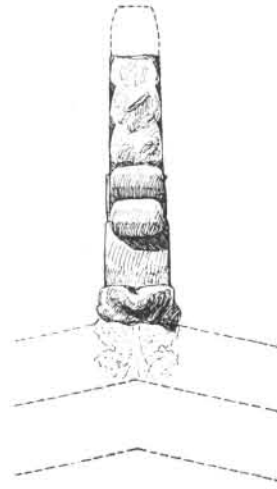

BLOC DE LA SIMA ET ANTÉFIXES.

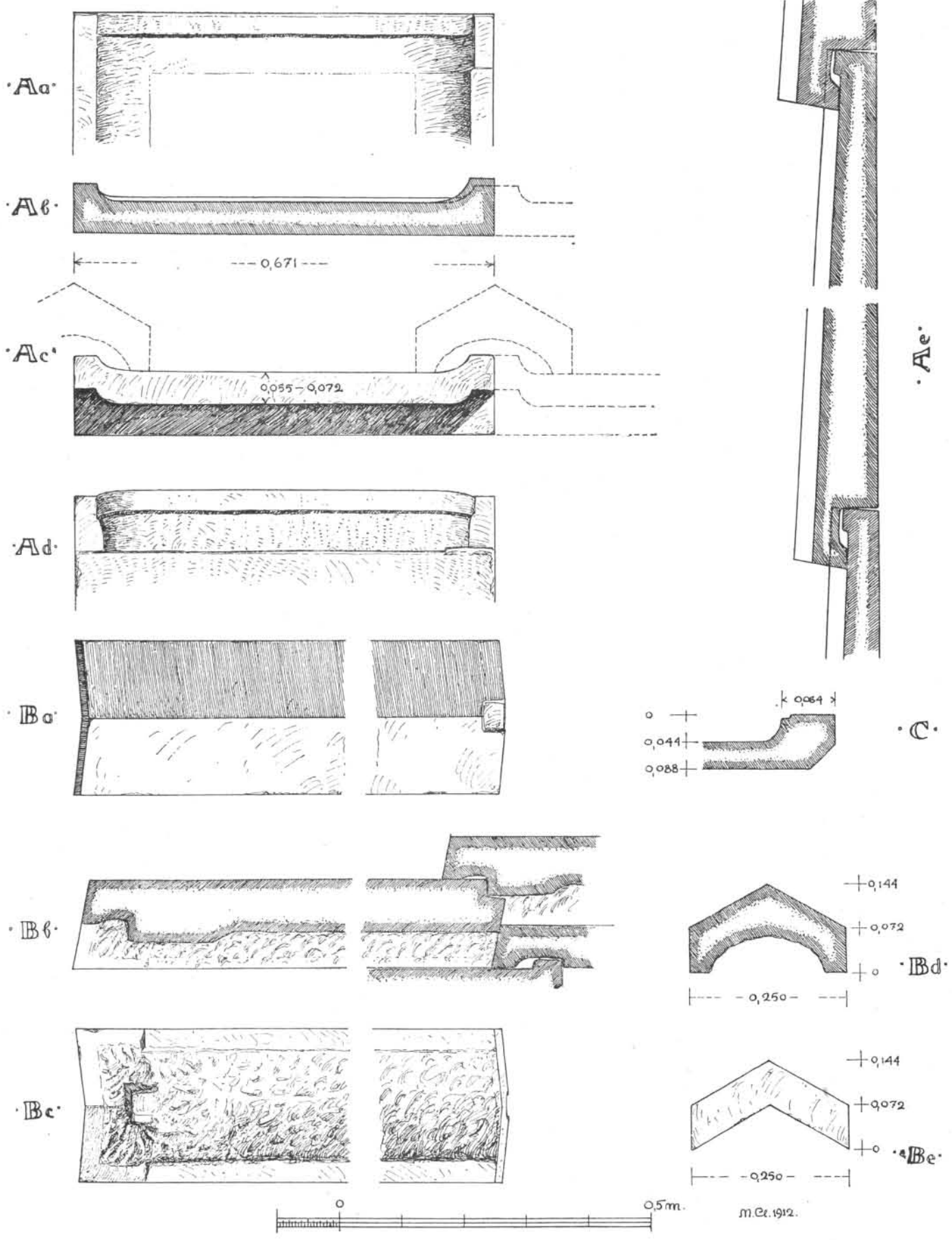

· A b ·

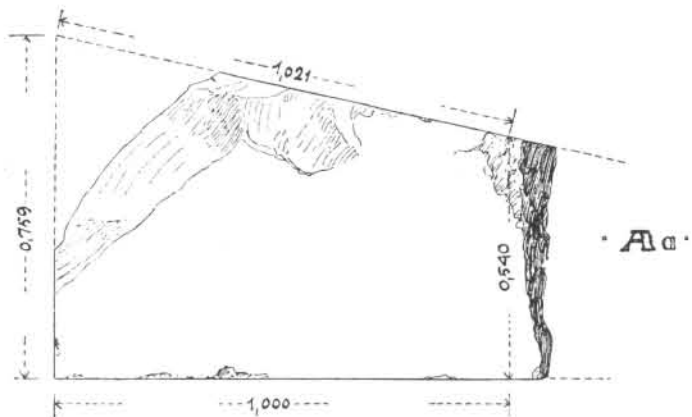
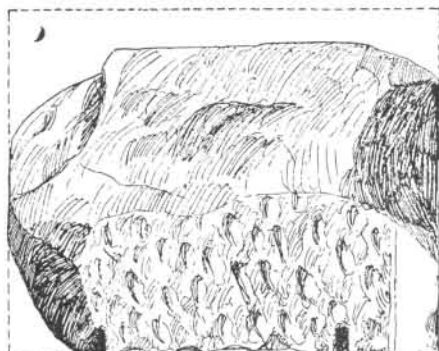

M. Cf. 1912

· A a ·

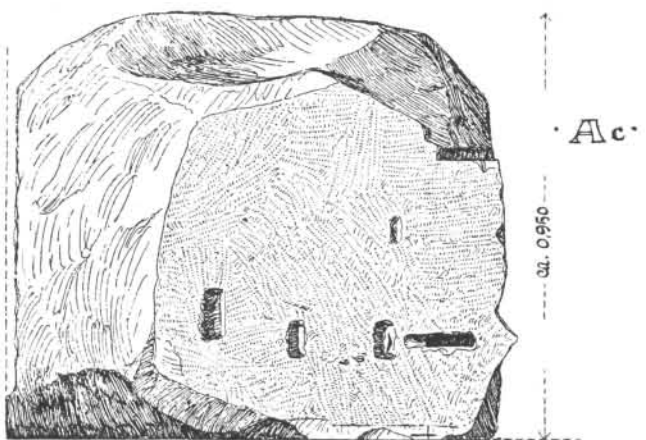

· A c ·

· B a ·



M. Cf. 1912

· B b ·

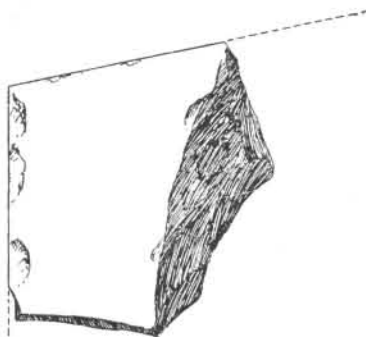

· B c ·

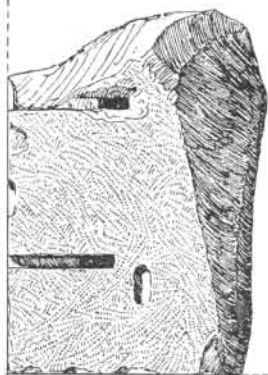

BLOCS DES TYMPANS.

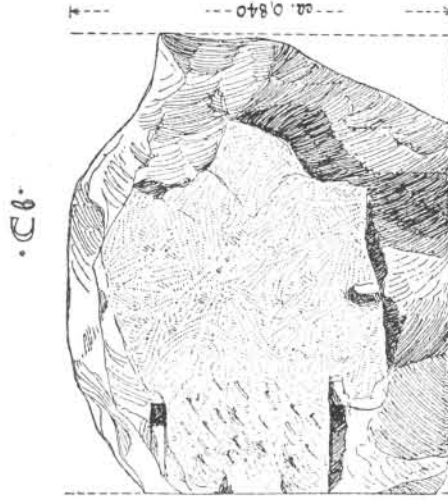
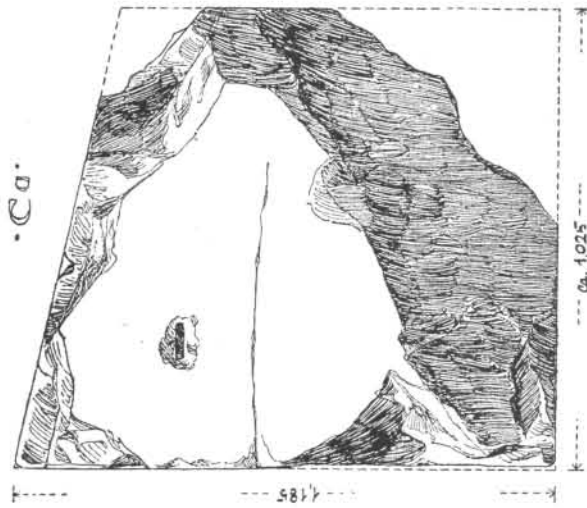

n. 21 1911.

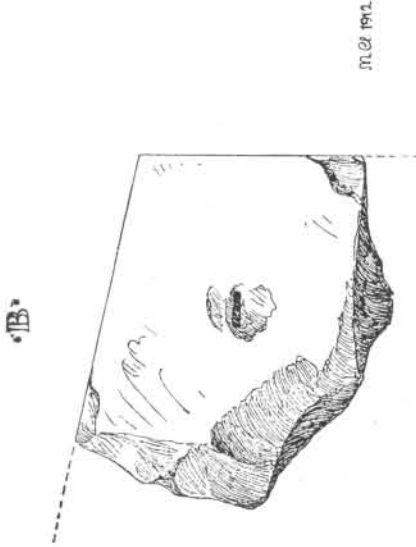
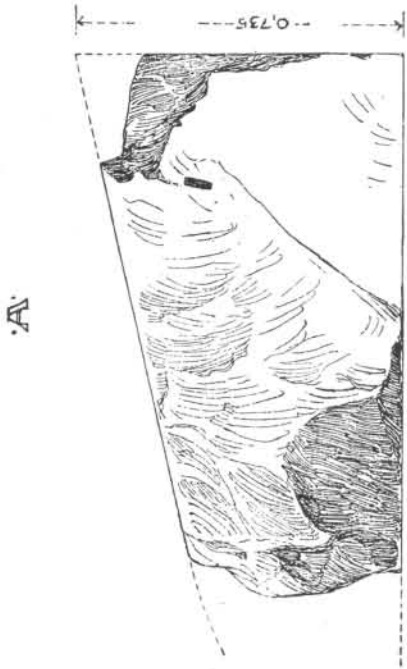

n. 21 1911.



BLOCS DU TYMPAN OUEST.

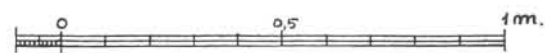
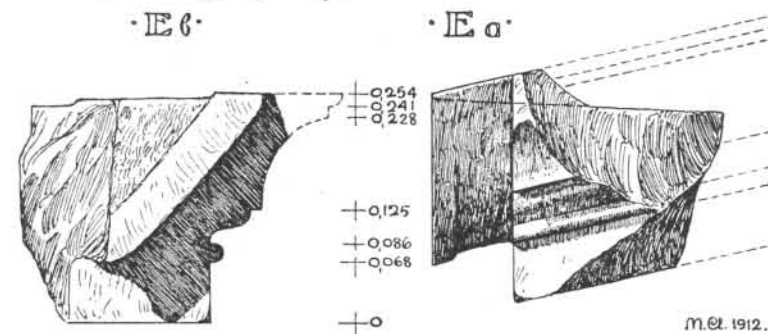
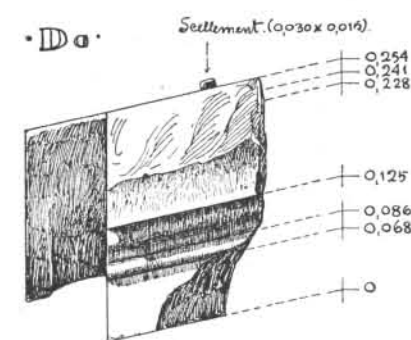
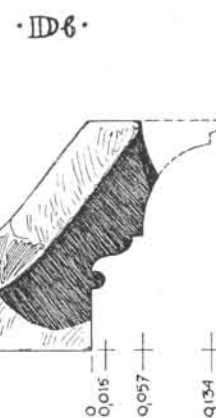
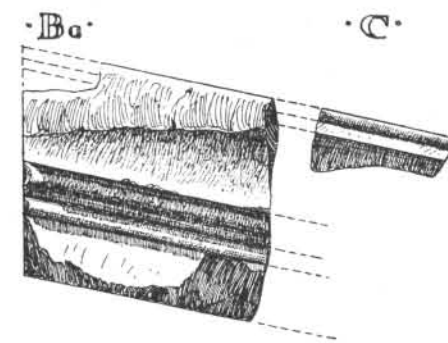
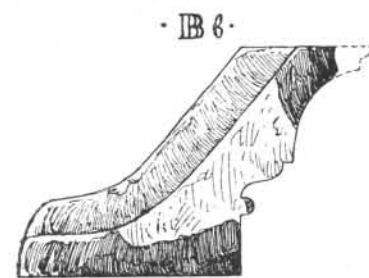
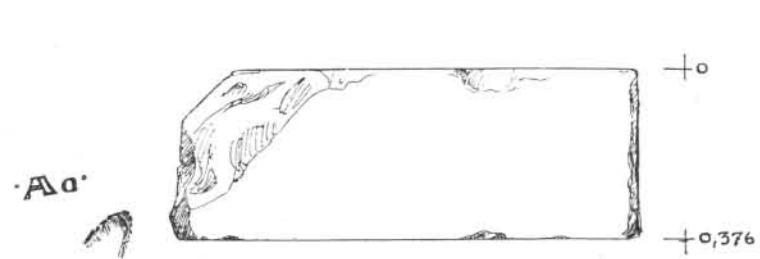

PARPAING DU MUR DE LA CELLA ET BLOCS DE LA SIMA DU FRONTON.

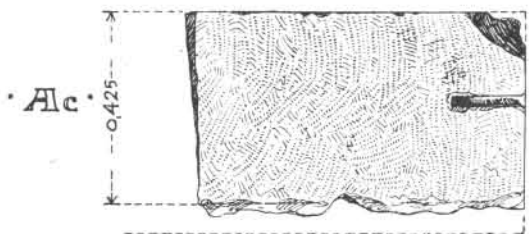
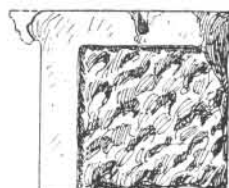
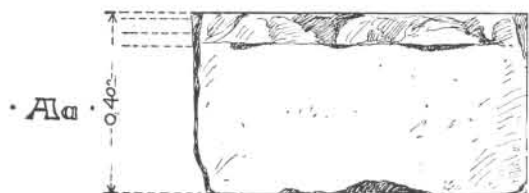

M. Et. 1912

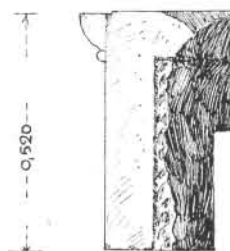
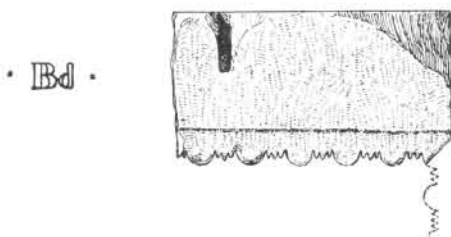
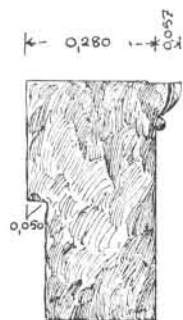
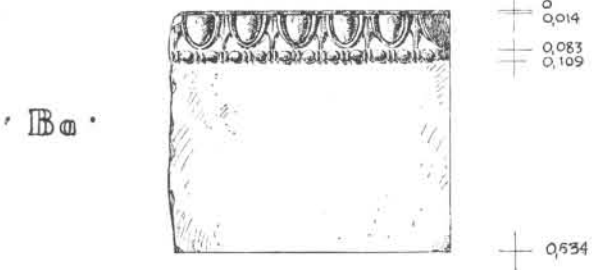

M. Et. 1912.



BLOCS DU COURONNEMENT DU PÉRISTYLE.

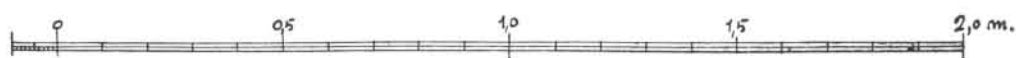
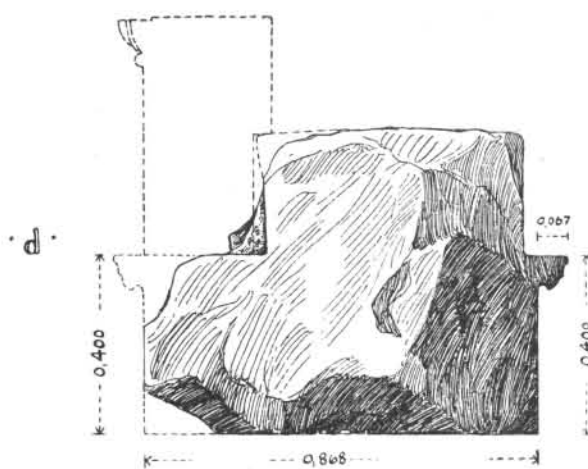
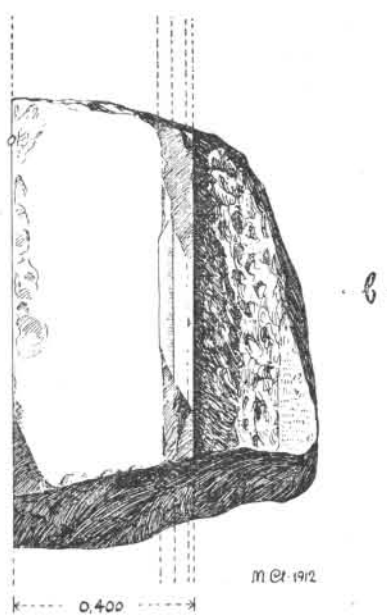
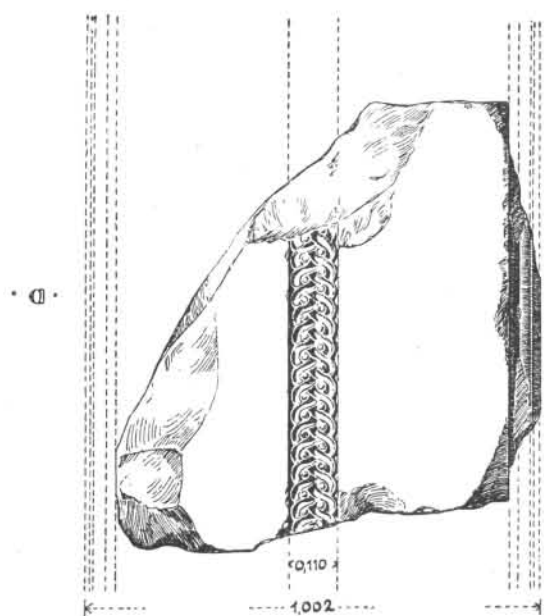

POUTRE DU PÉRISTYLE.

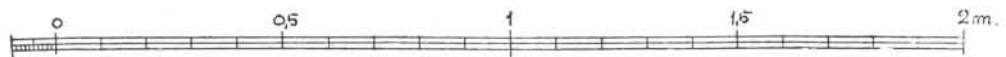
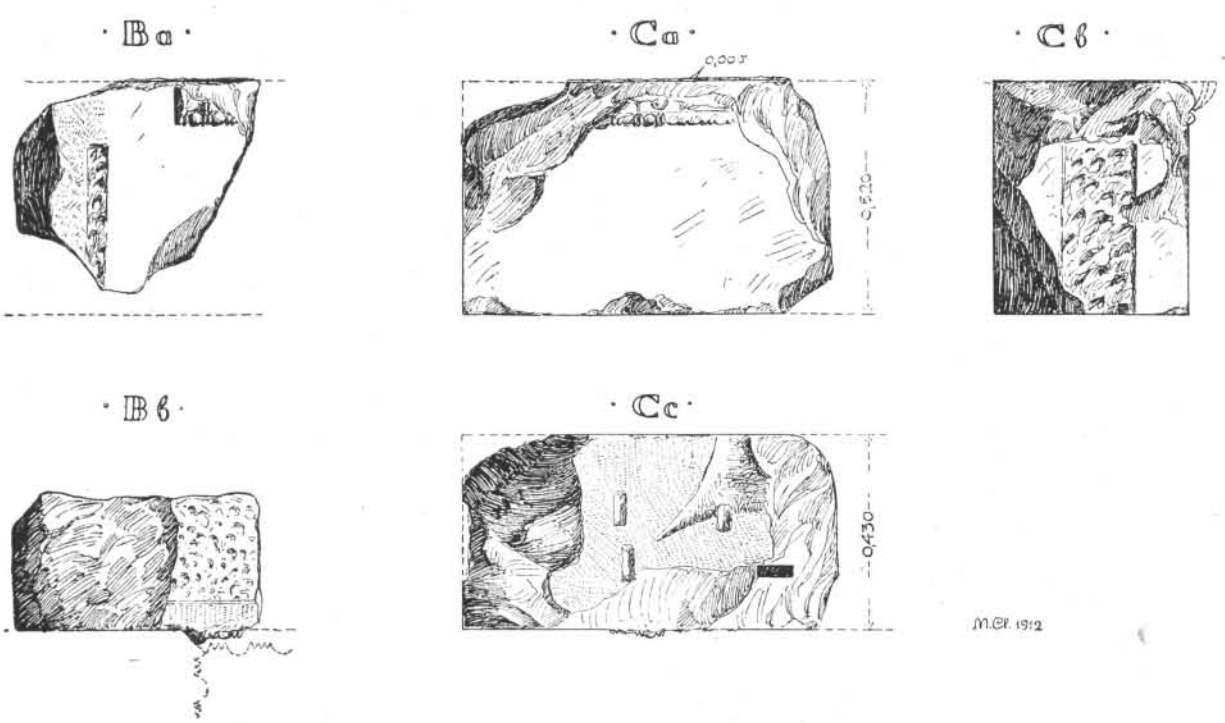
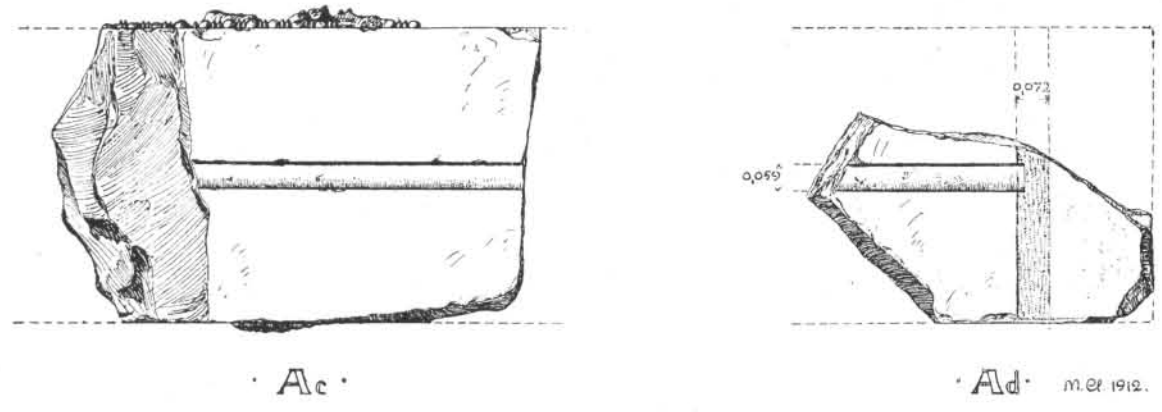
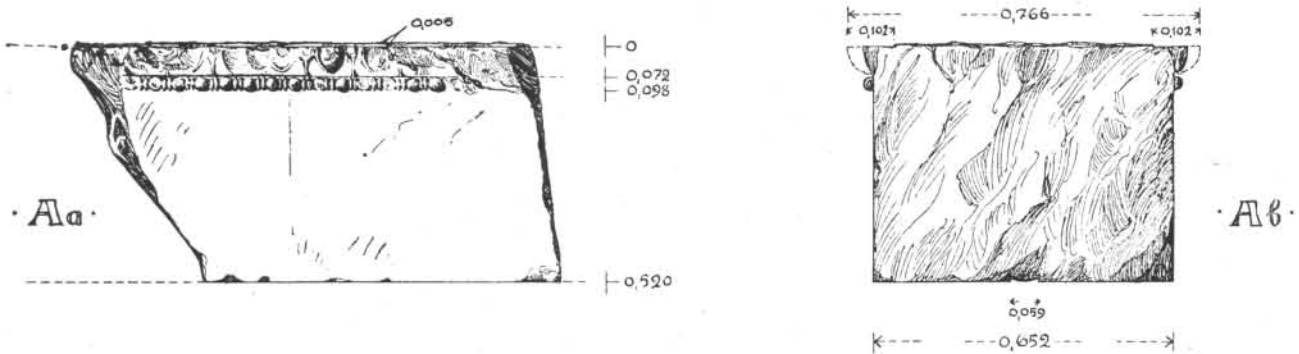

SOLIVES ET COURONNEMENT DU PÉRISTYLE (PETITS COTÉS) ET DU PRONAOS.

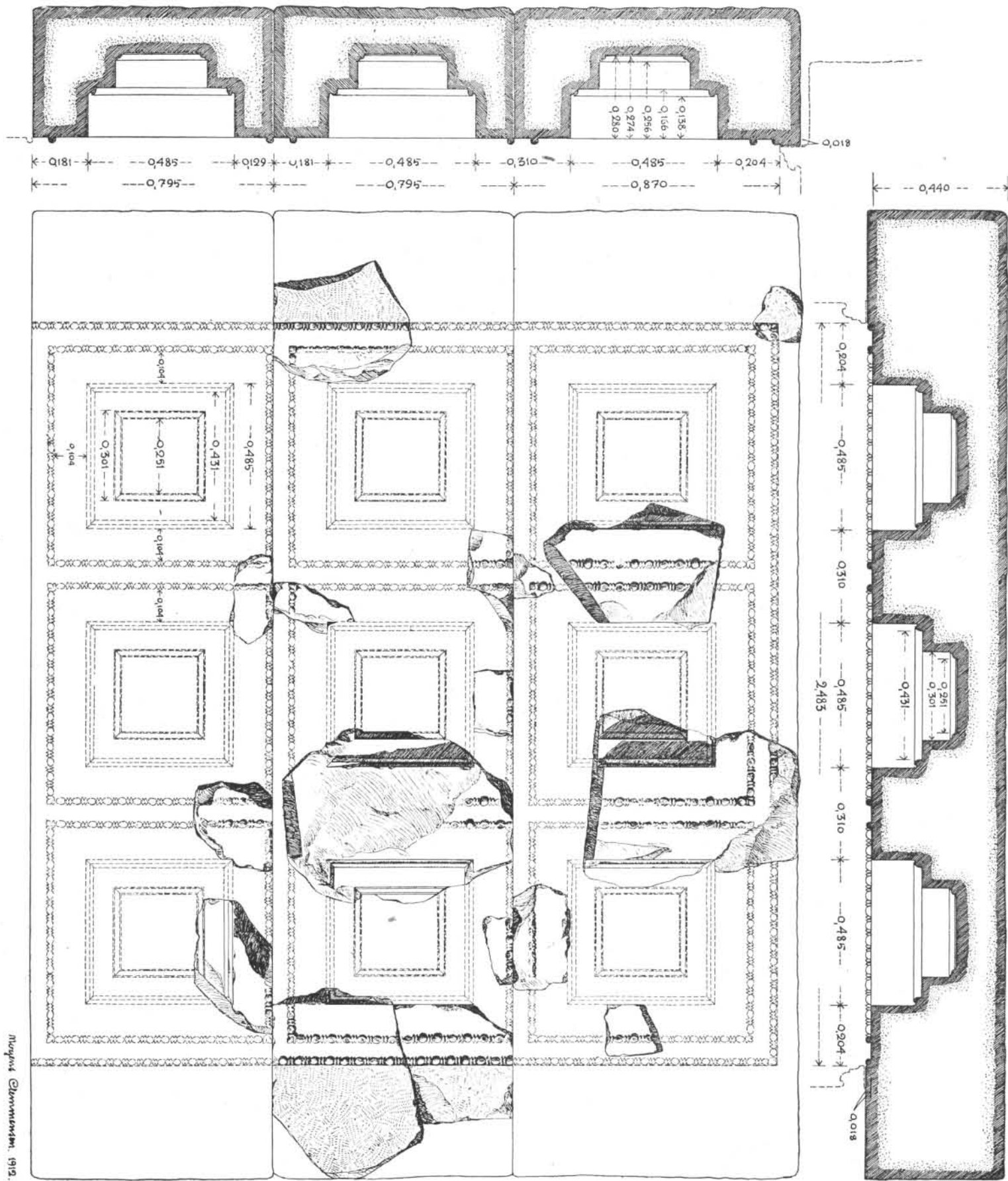

Musées Clémenceau, 1912.

SOFFITES DU PÉRISTYLE (LONGS COTÉS).

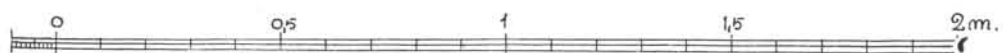
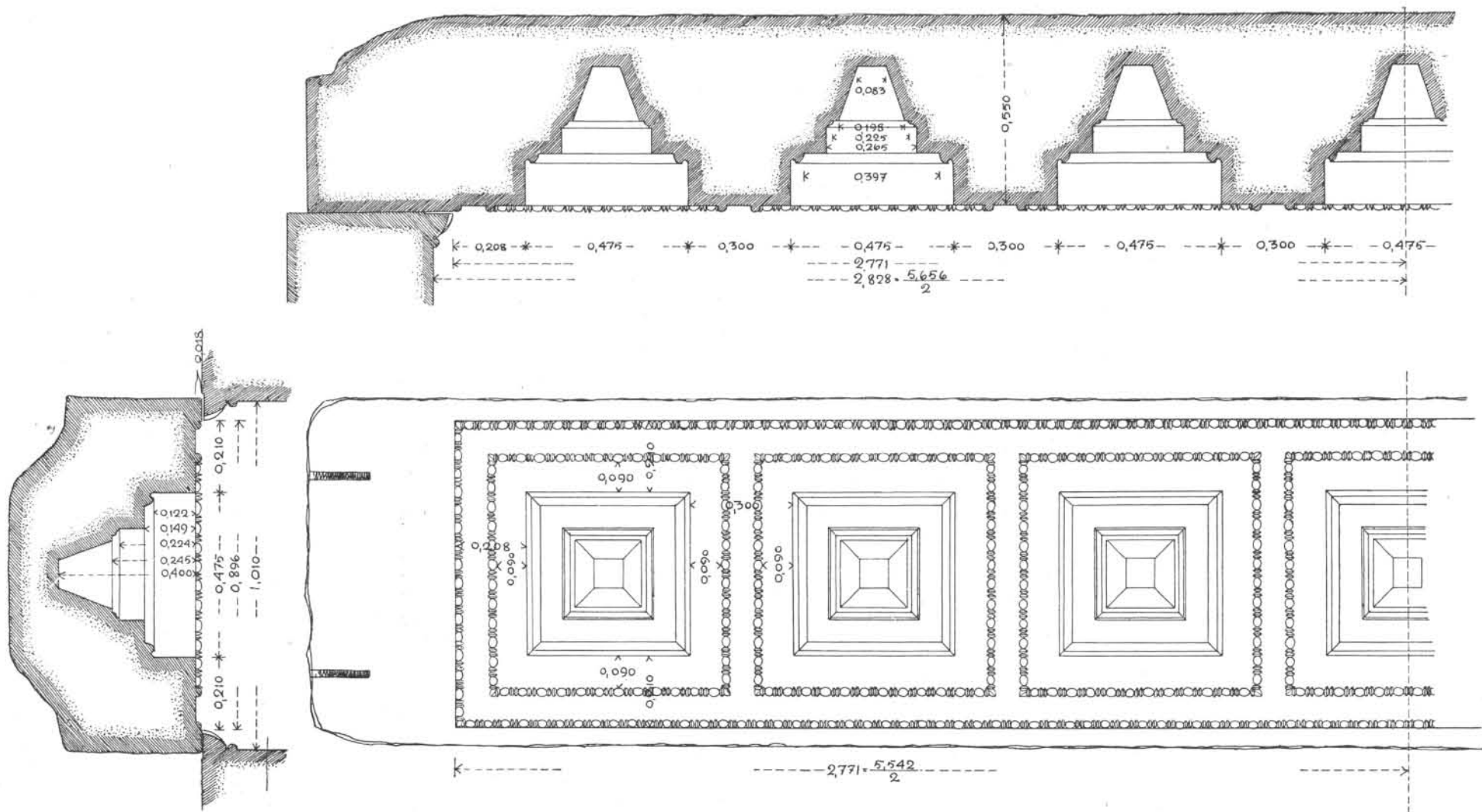

SOFFITE DU PÉRISTYLE (PETITS COTÉS) ET DU PRONAOS.

M. Et. 1914.



GRAND DIAMÈTRE: 1,052.
 PETIT DIAMÈTRE: 0,998.

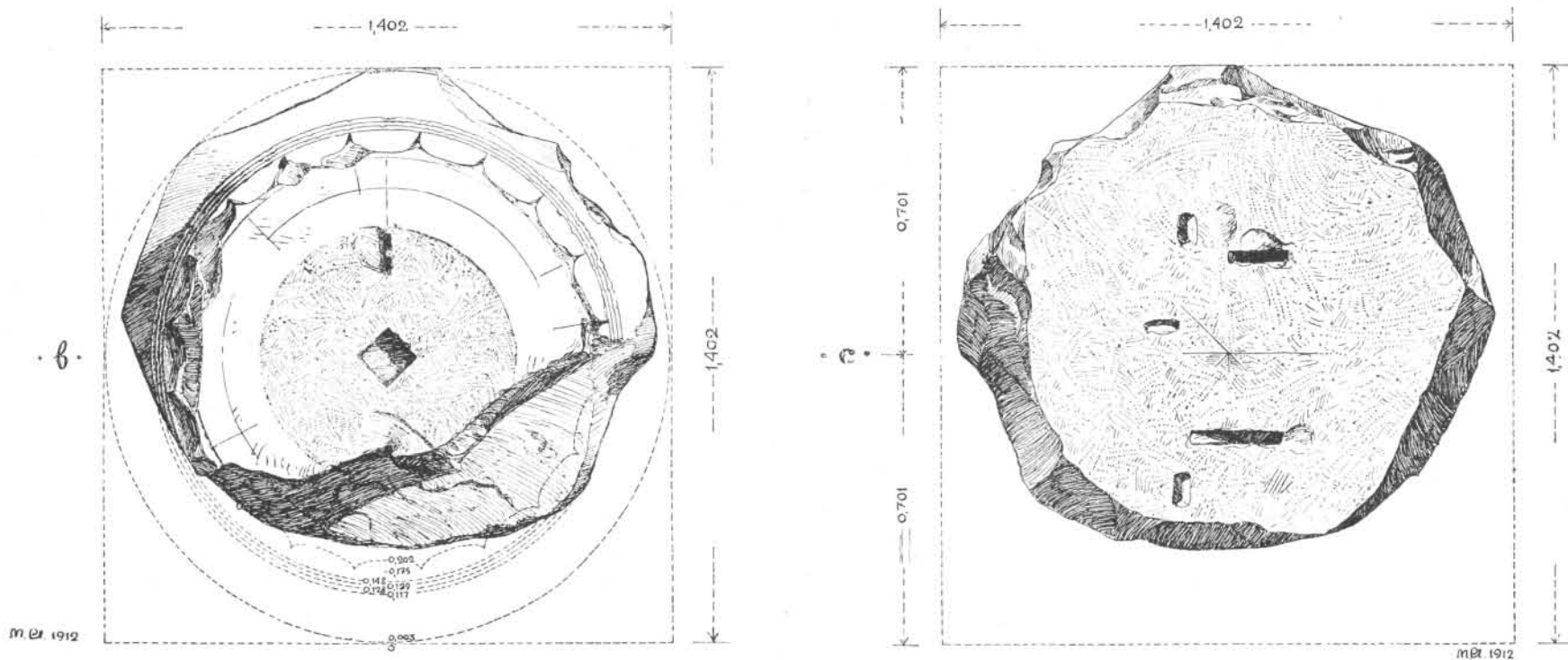

CHAPITEAU DU PRONAOS.

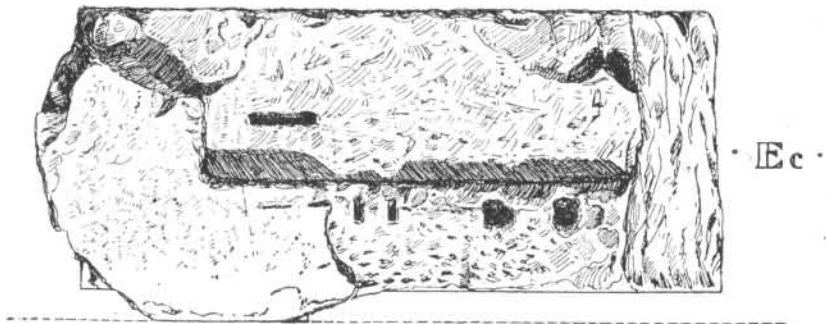
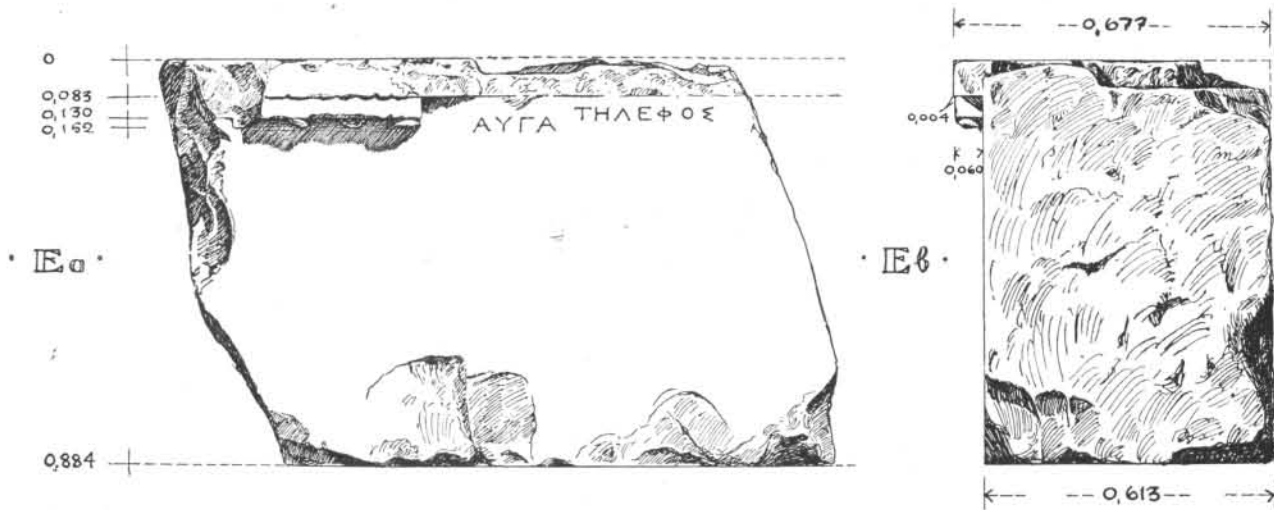
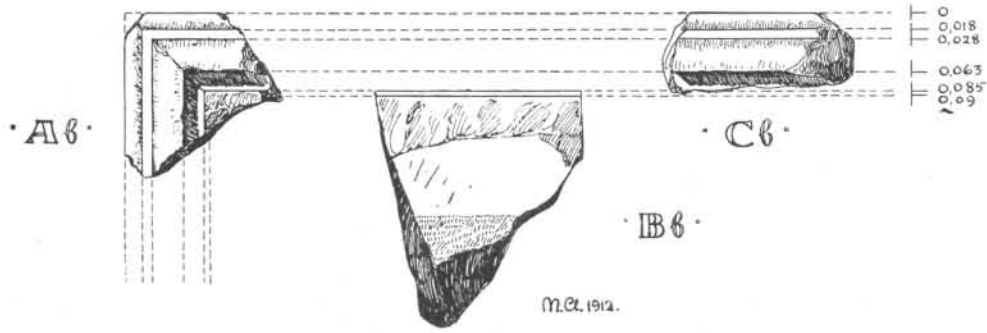
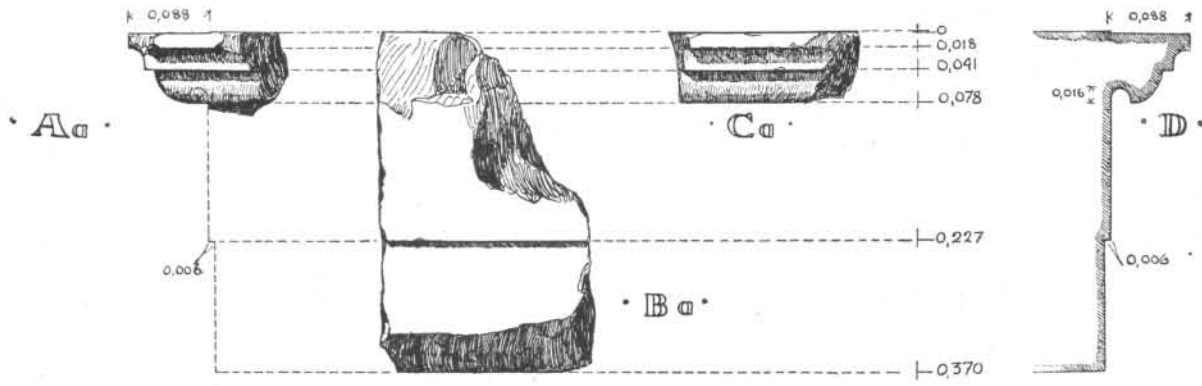

M.C. 1912



CHAPITEAU D'ANTE ET ARCHITRAVE DE L'OPISTHODOME.

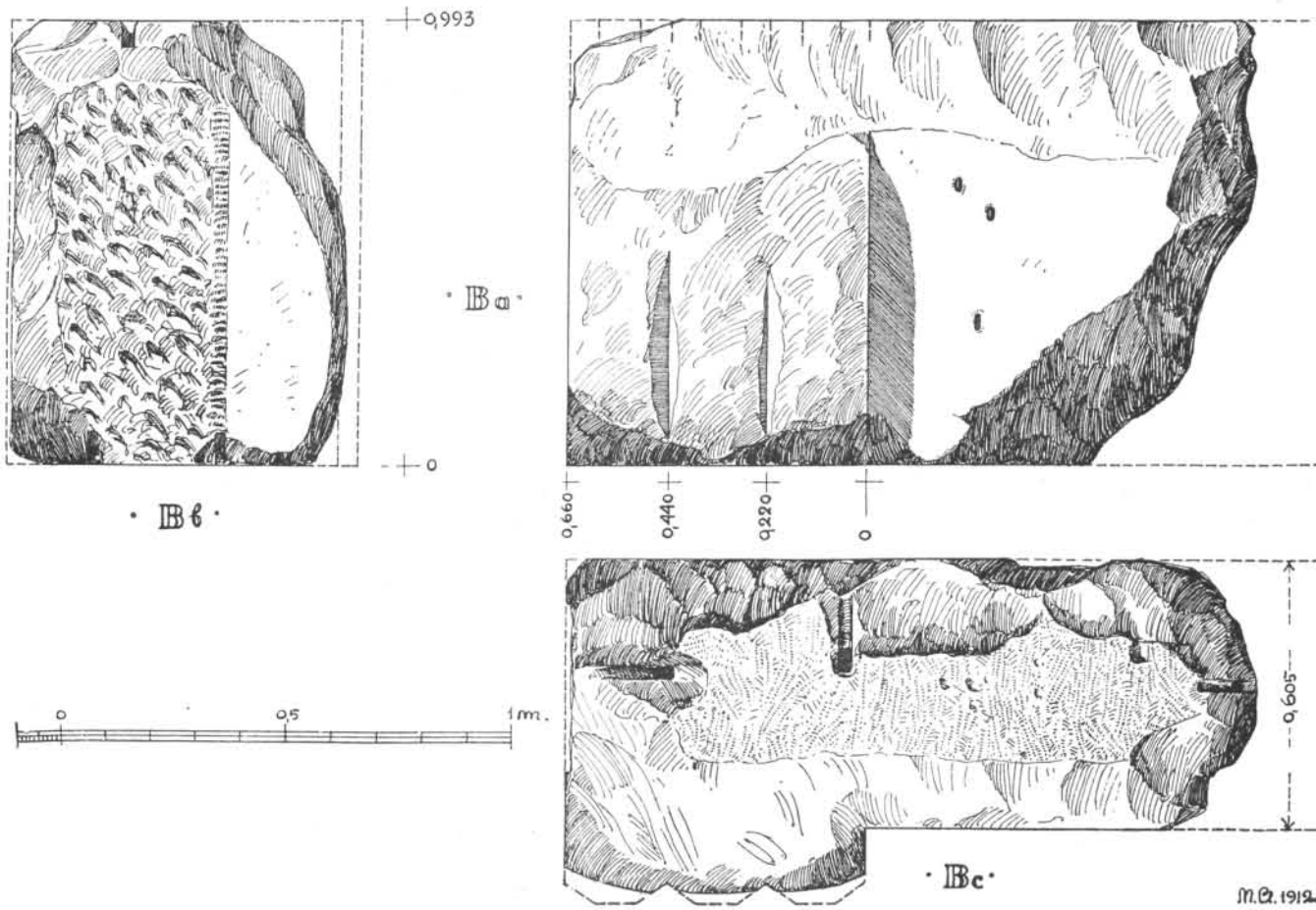
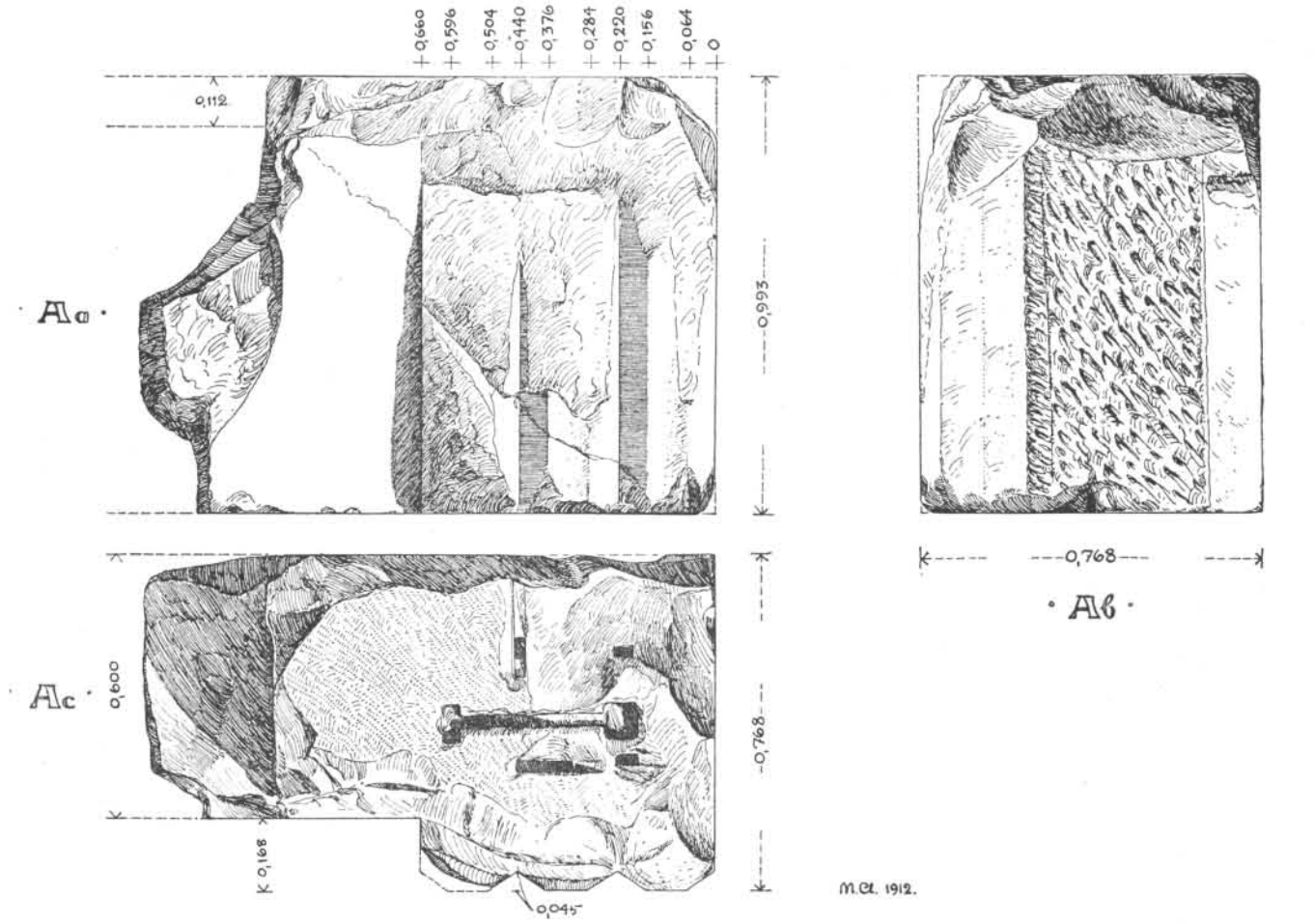

BLOCS DES FRISES DE L'OPISTHODOME ET DU PRONAOS.

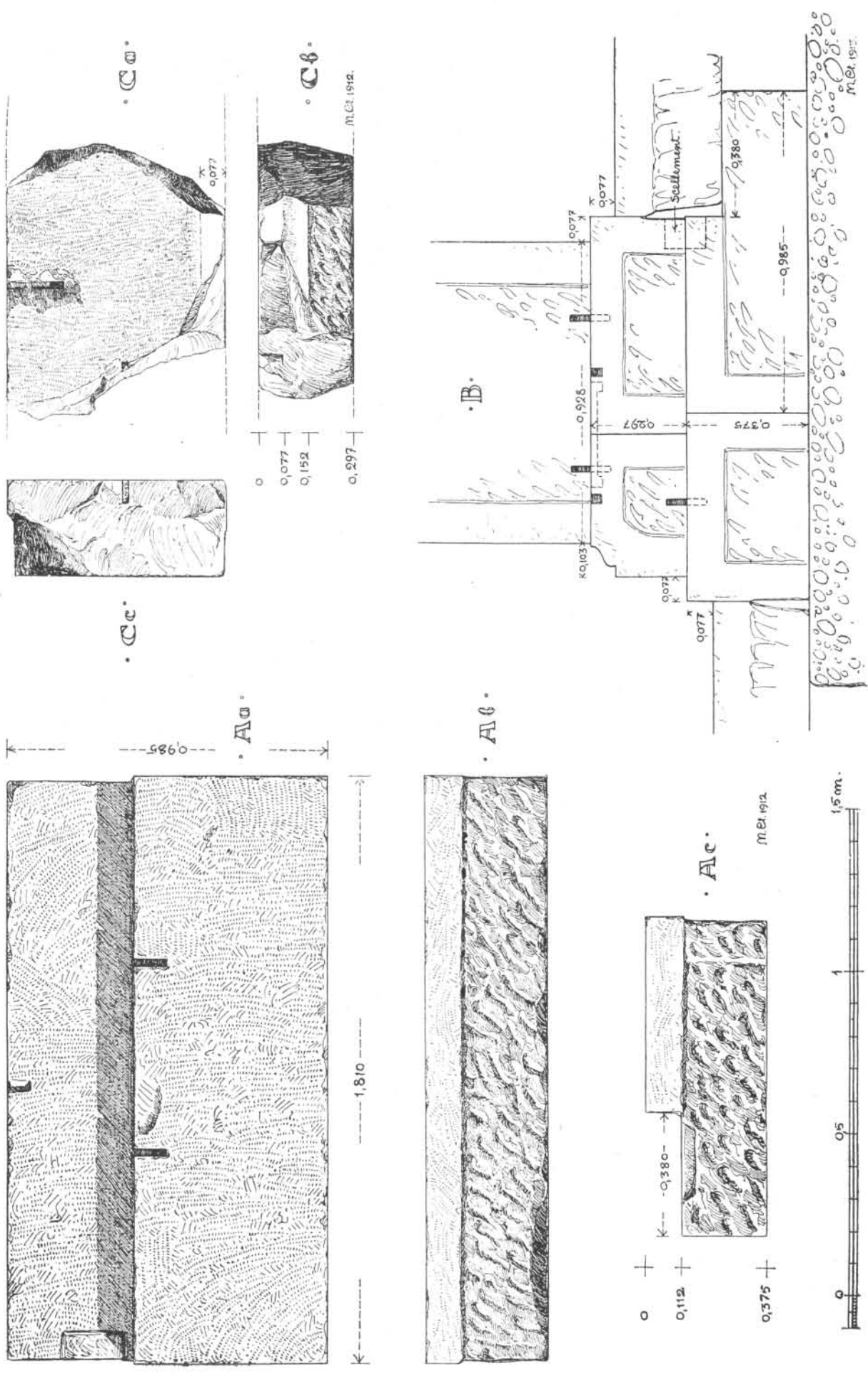

BLOCS ET COUPE DU TOICHOBATE.

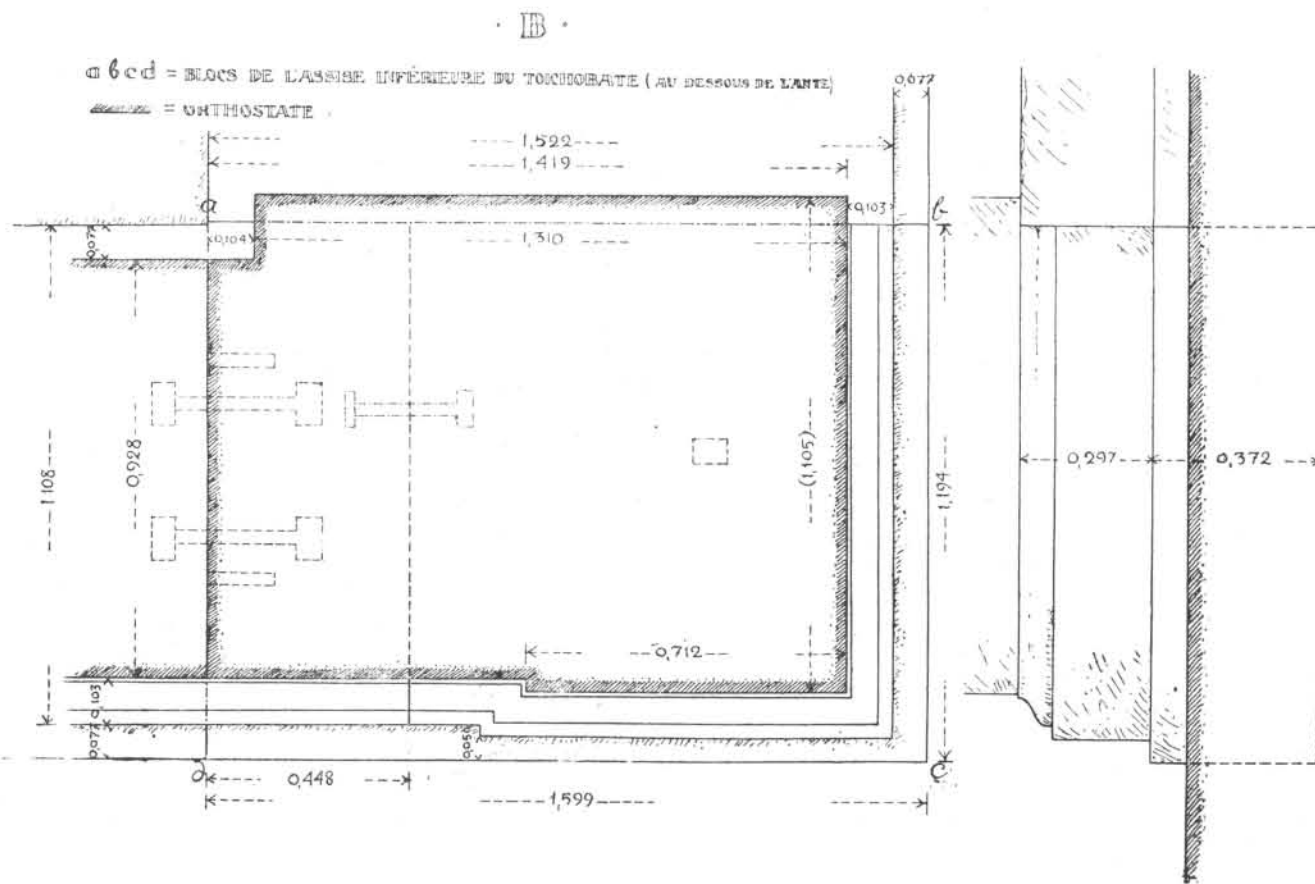
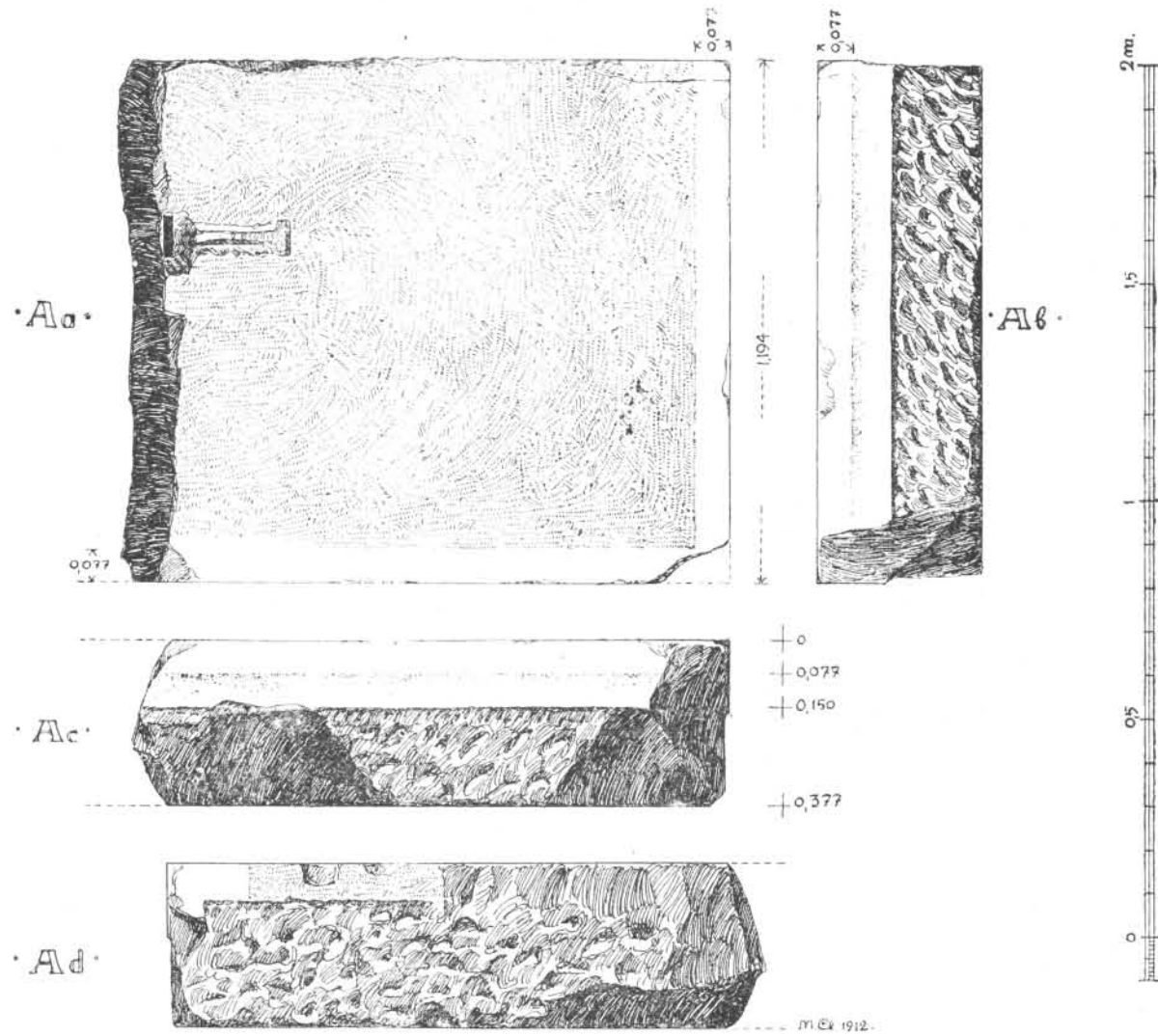

BLOC ET PLAN DU TOICHOBATE.

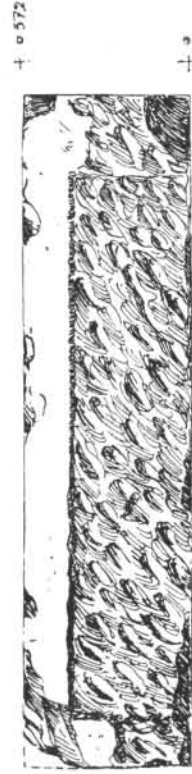
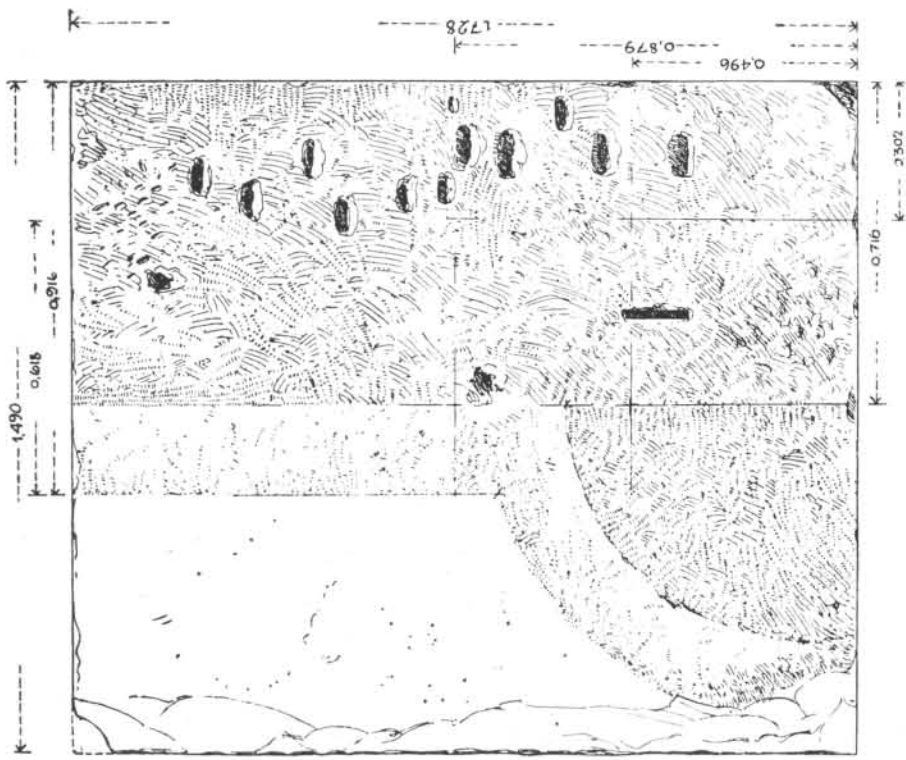

-Bb-



Bb-

BLOCS DU TOICHOBATE.

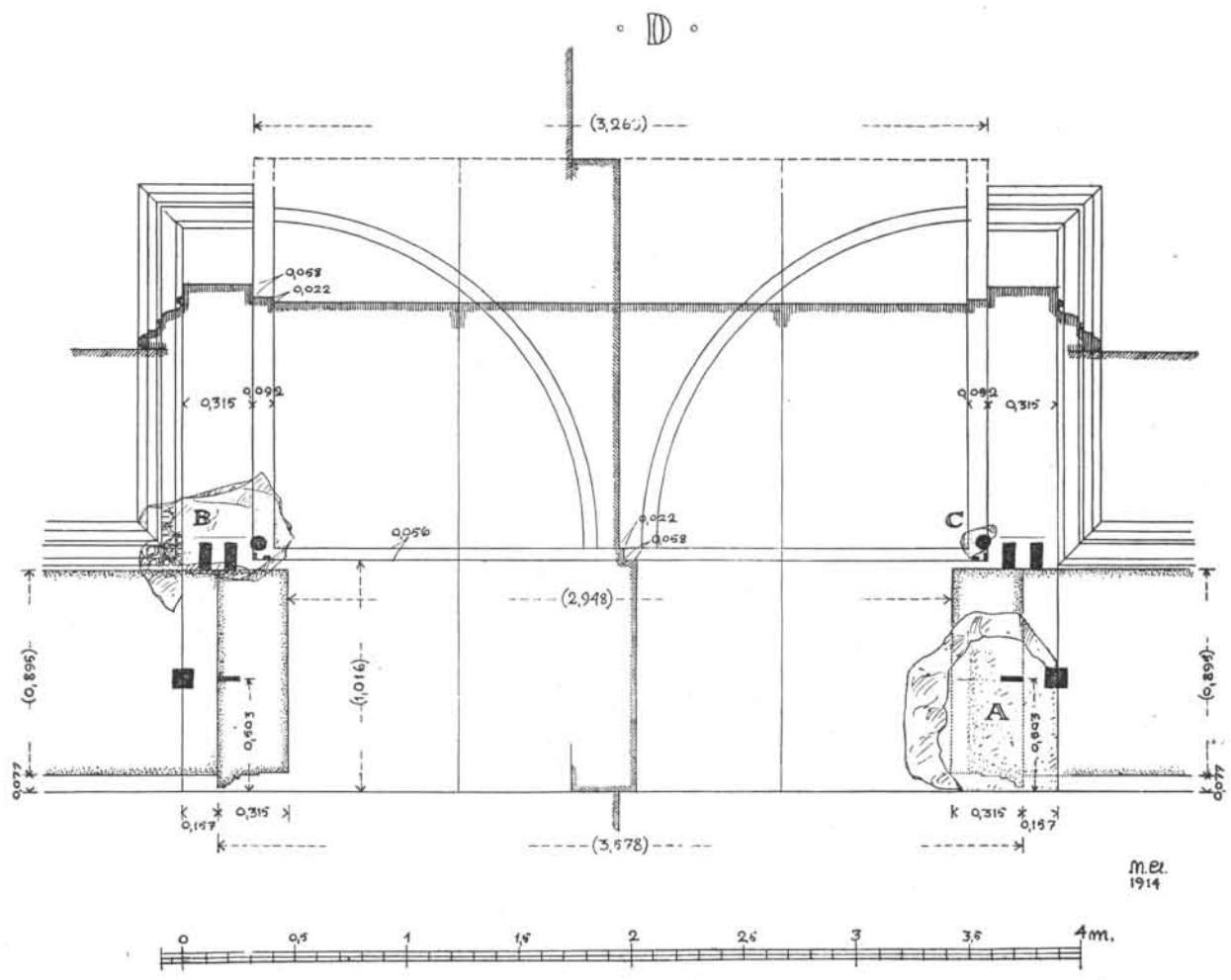
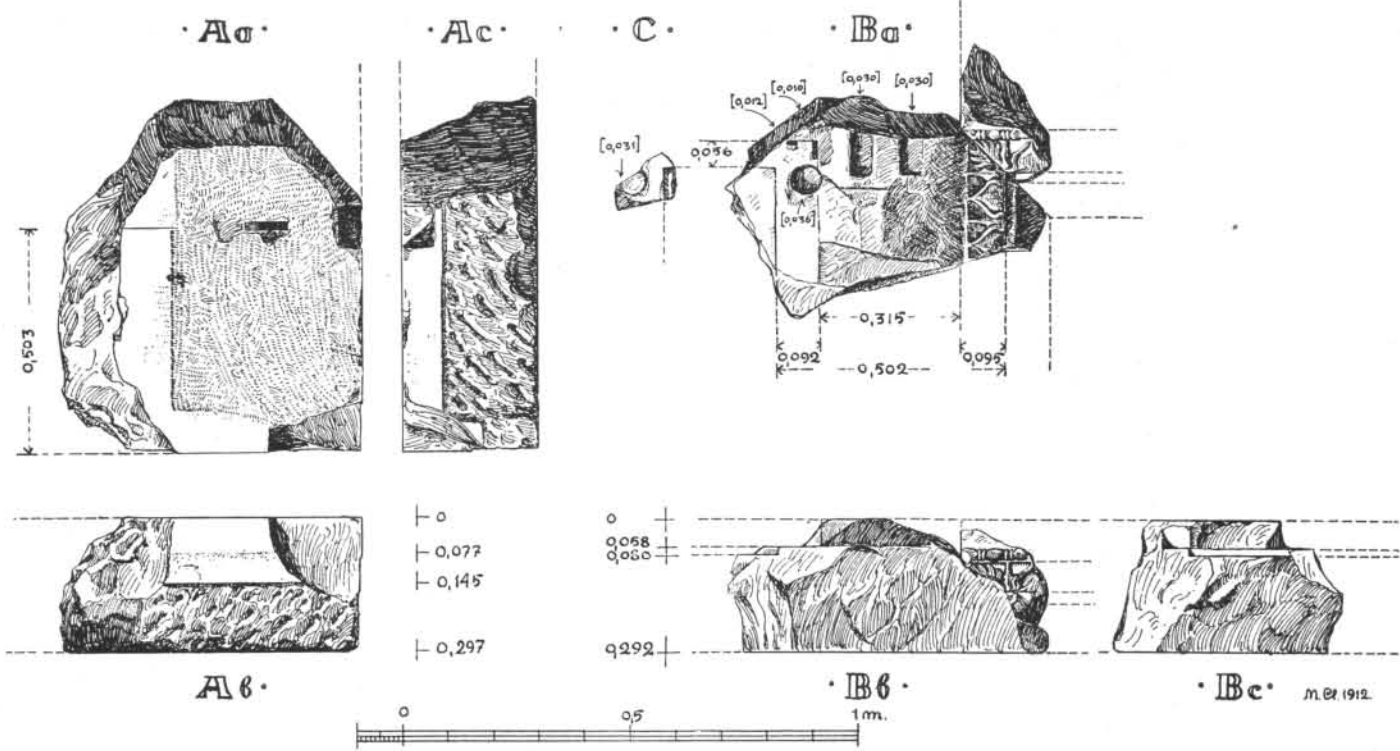

BLOCS DU TOICHOBATE ET PLAN DE LA PORTE.

m.él.
1914

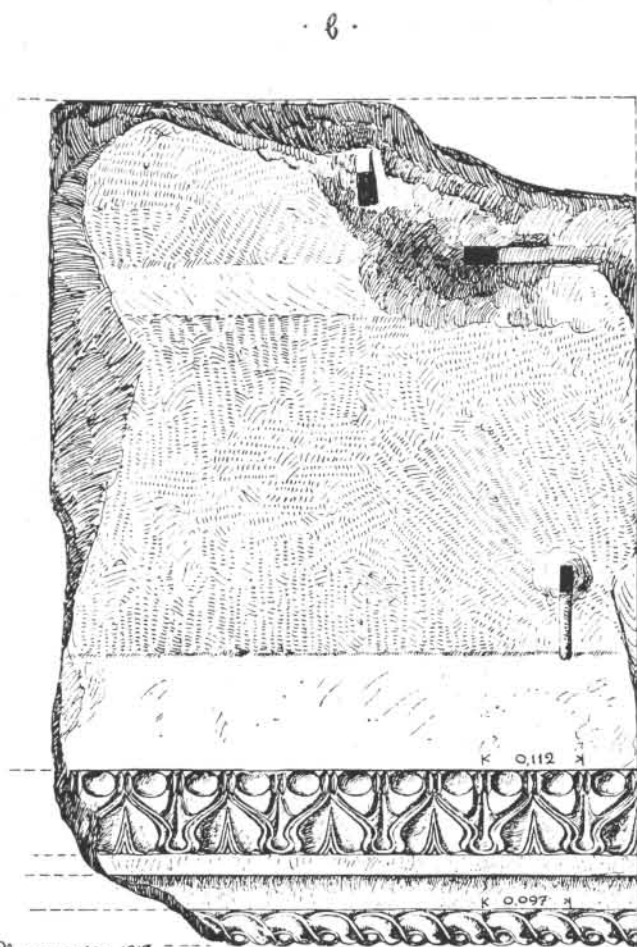
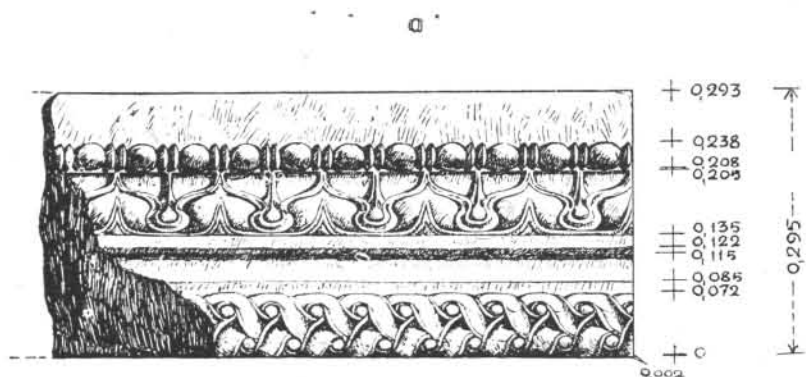

Mogensen Clemmensen 1913.

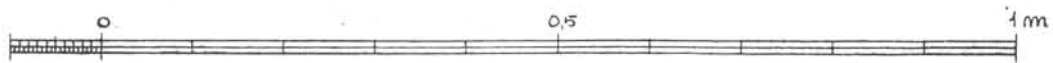
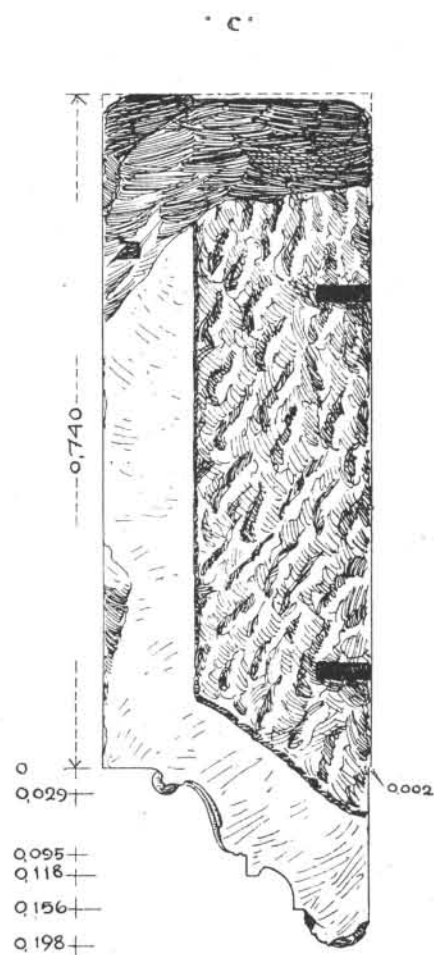

BLOC DU TOICHOBATE.

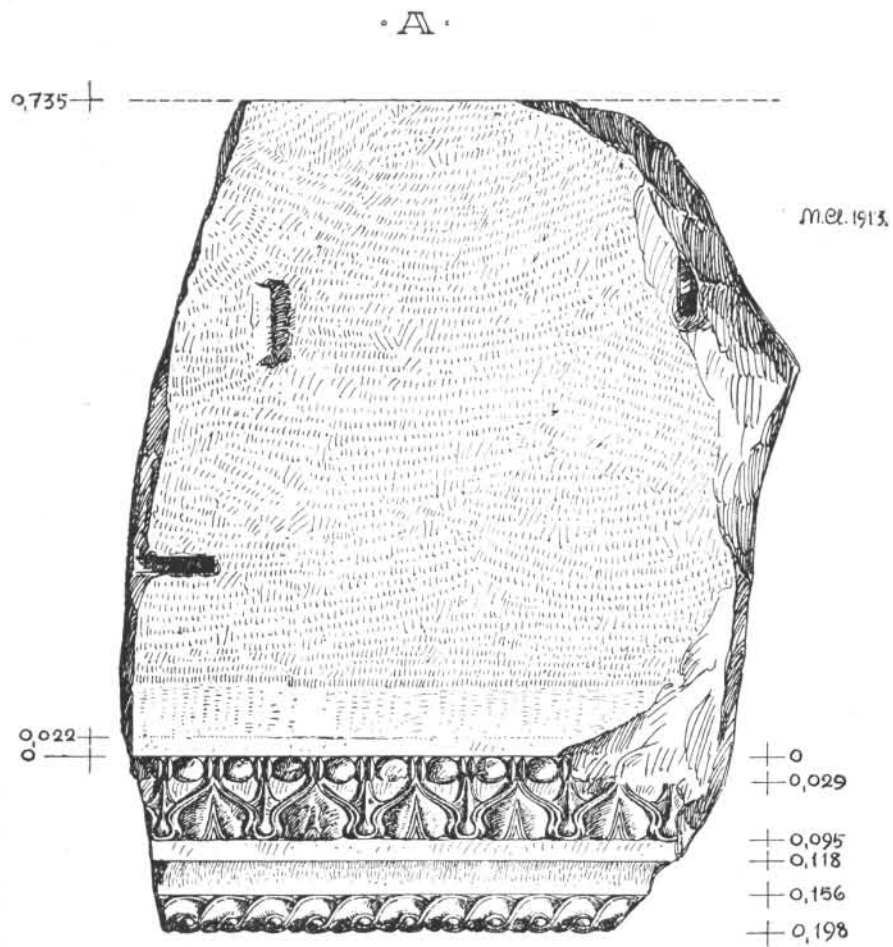
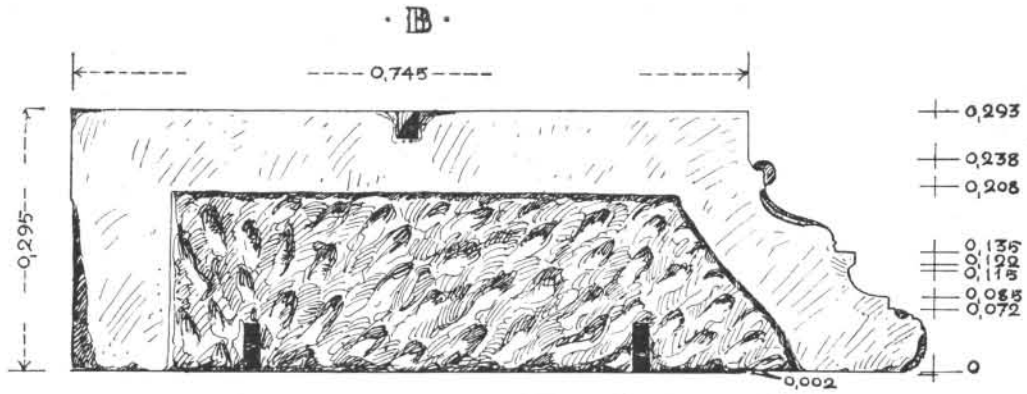

BLOCS DU TOICHORATE.

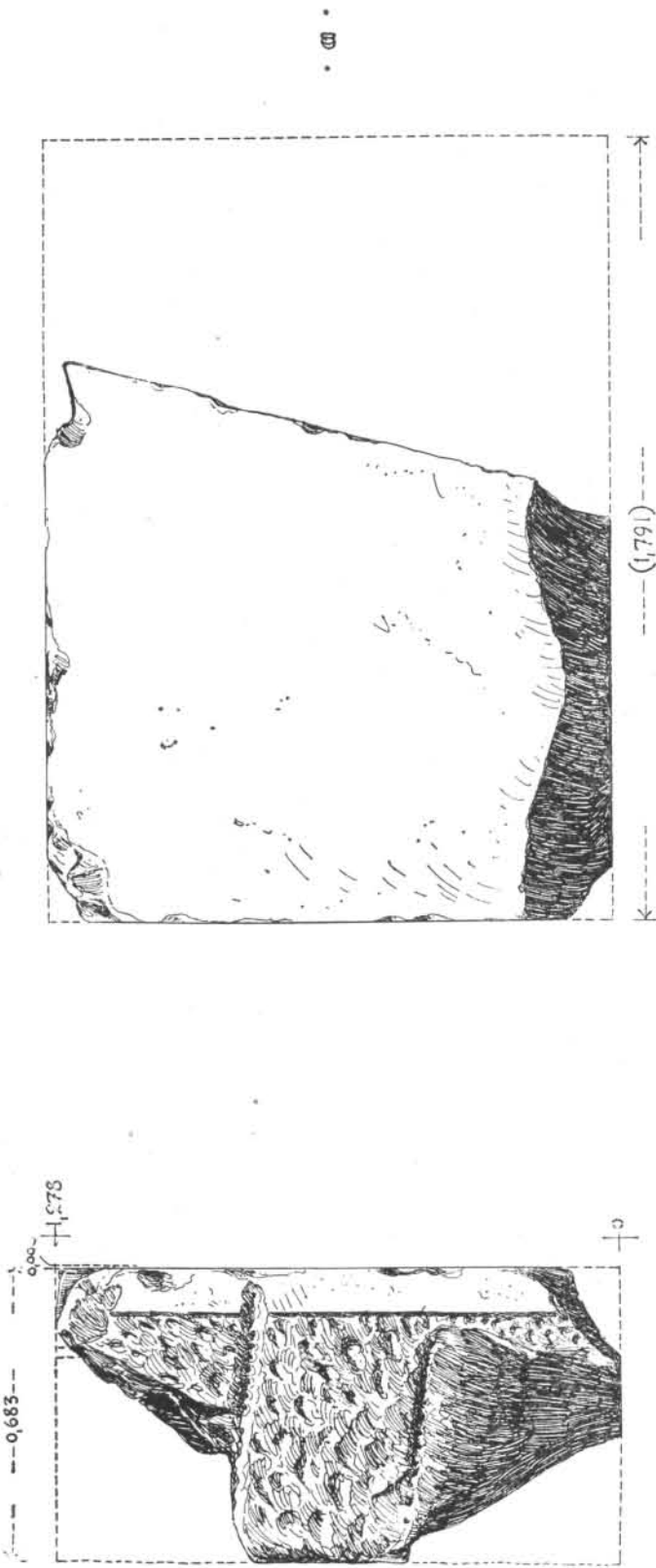

M. C. 1912.

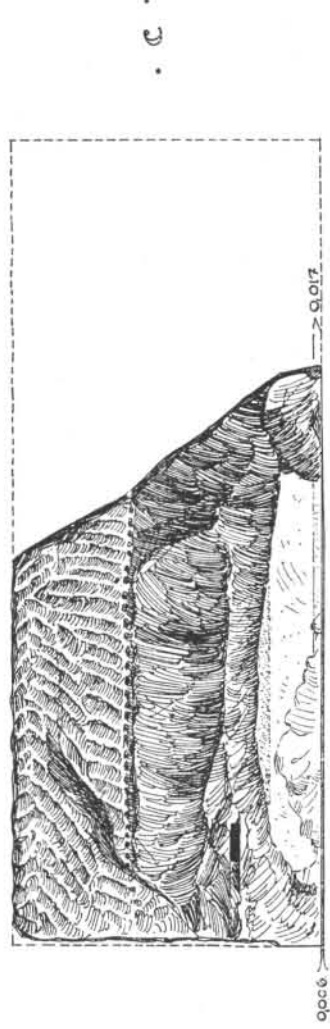

BLOC DE L'ORTHOSTATE.

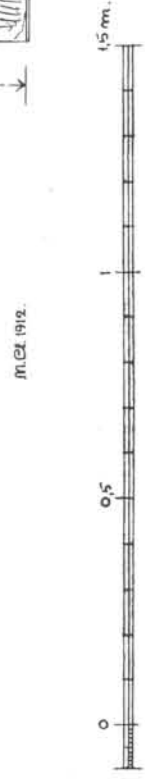
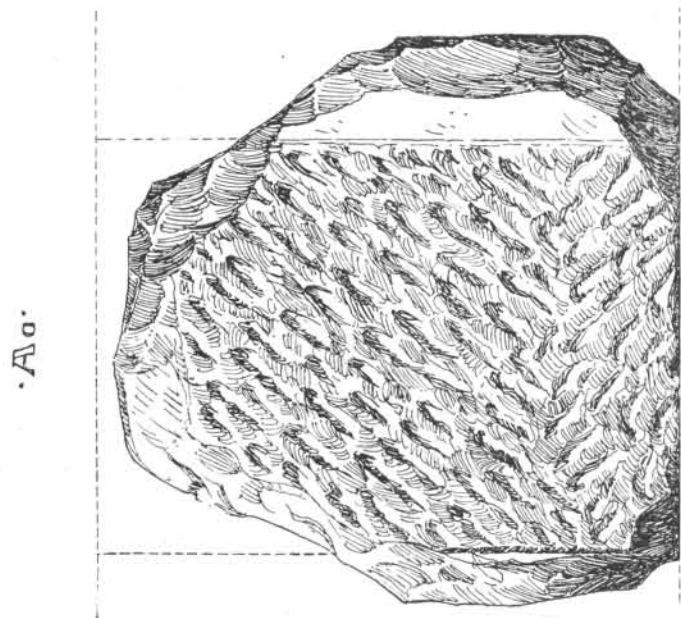
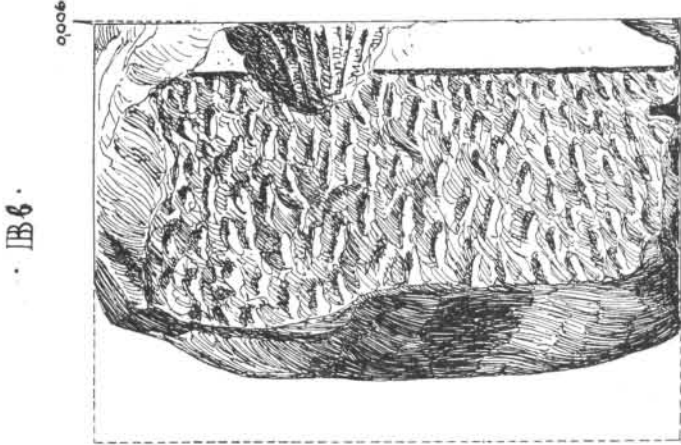
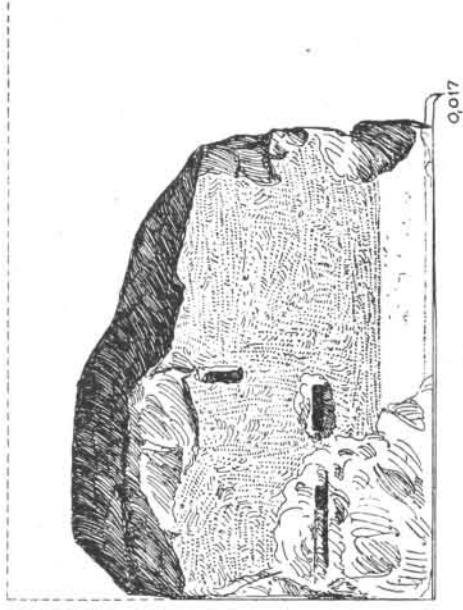
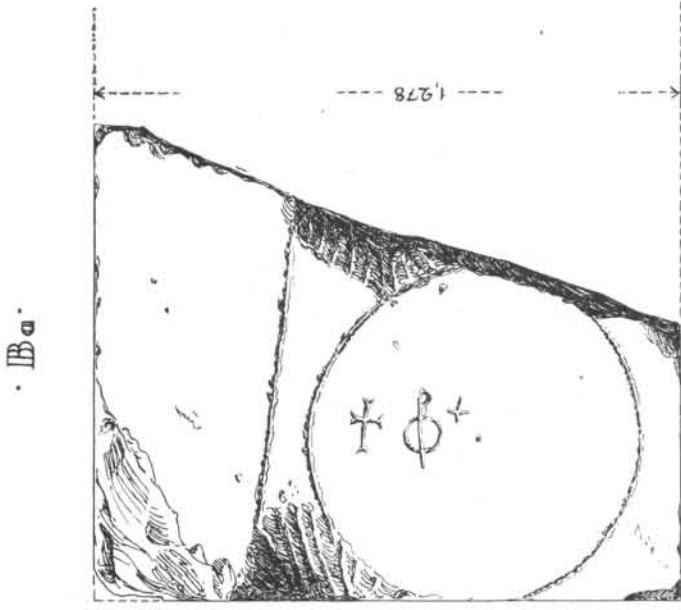

BLOCS DE L'ORTHOSTATE.

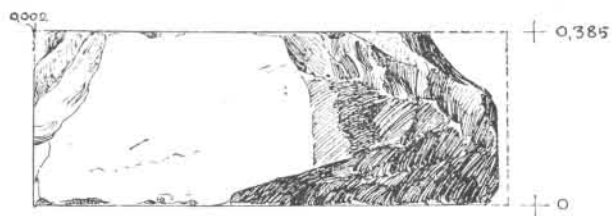

• a •

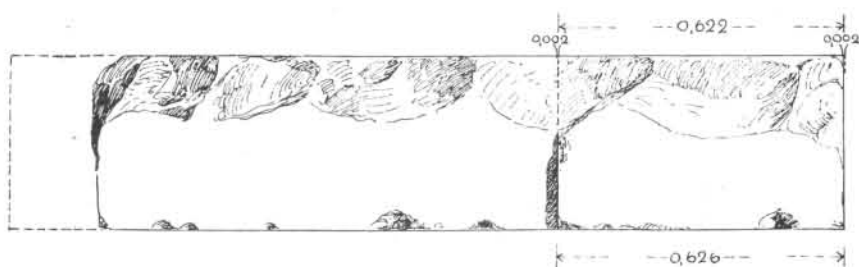

• b •

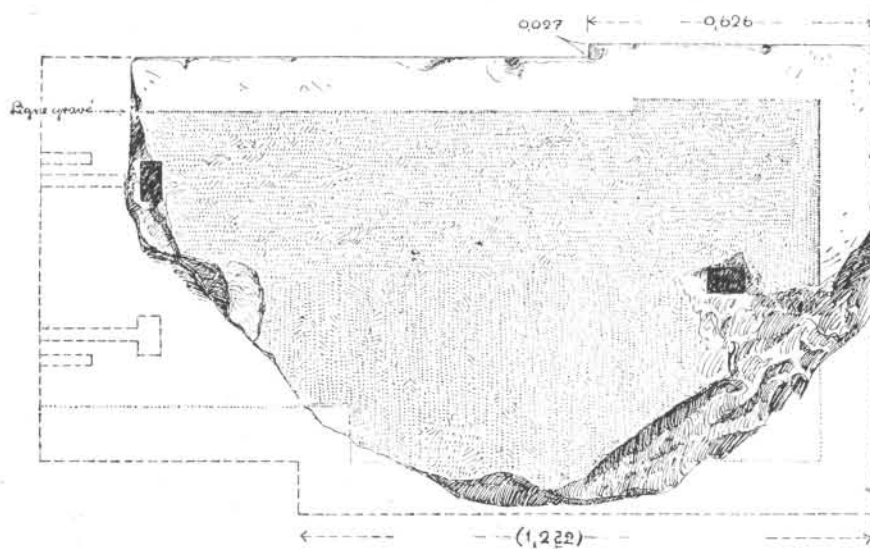

• c •

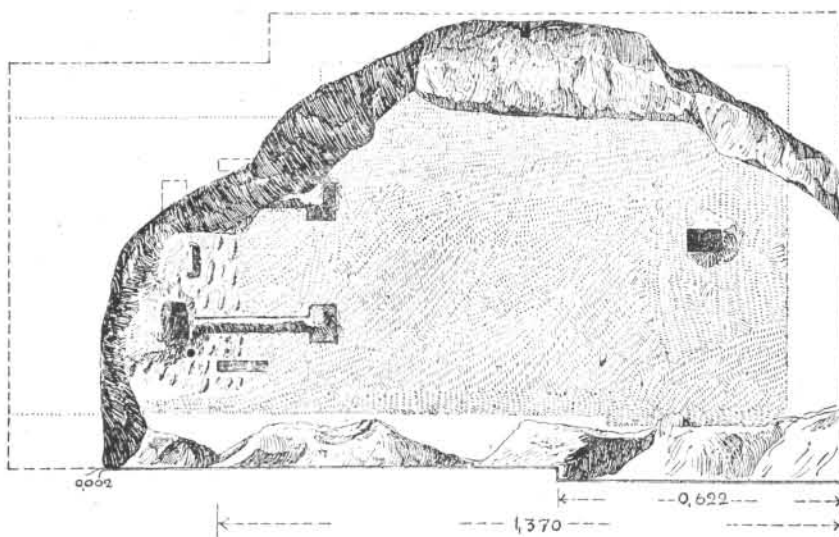

• d •

m. Cr. 1912



PARPAING DE L'ANTE.

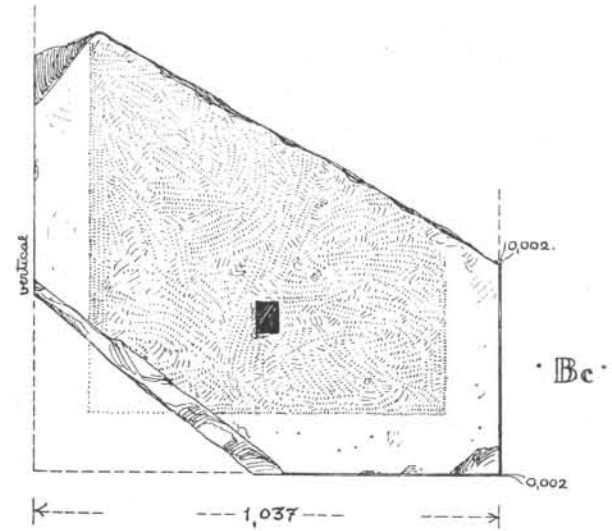
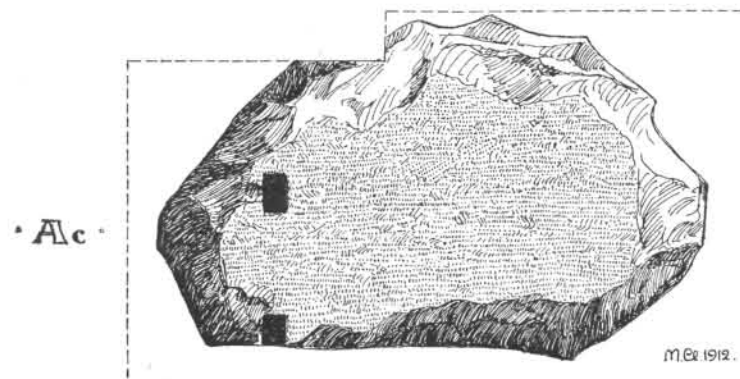
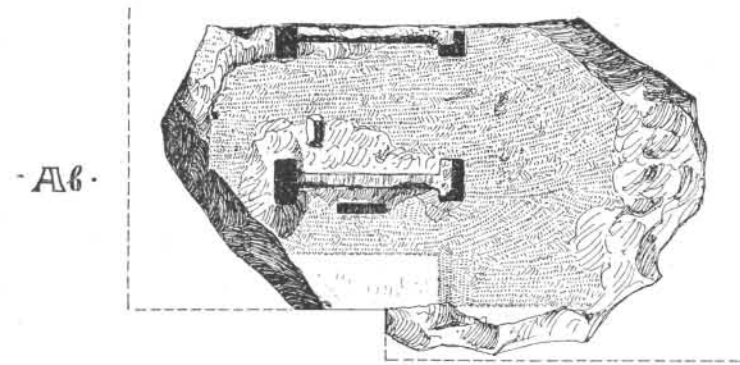
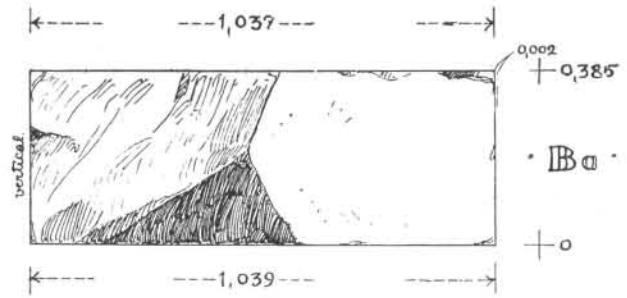
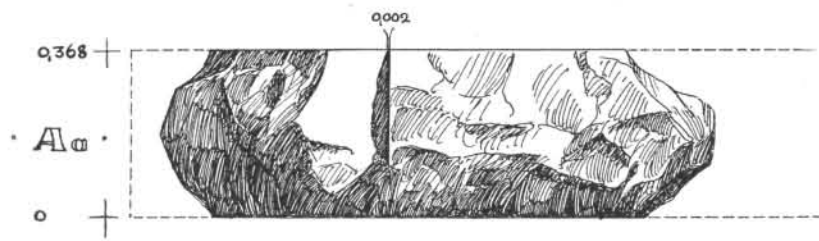

PARPAINGS DE L'ANTE.

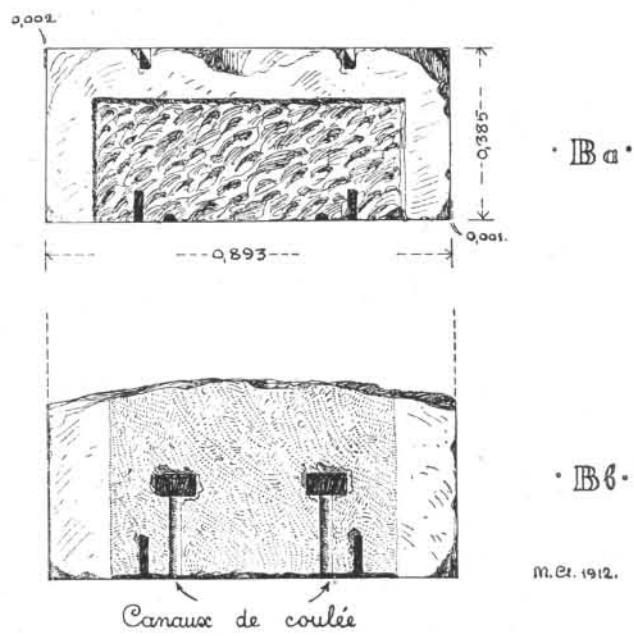
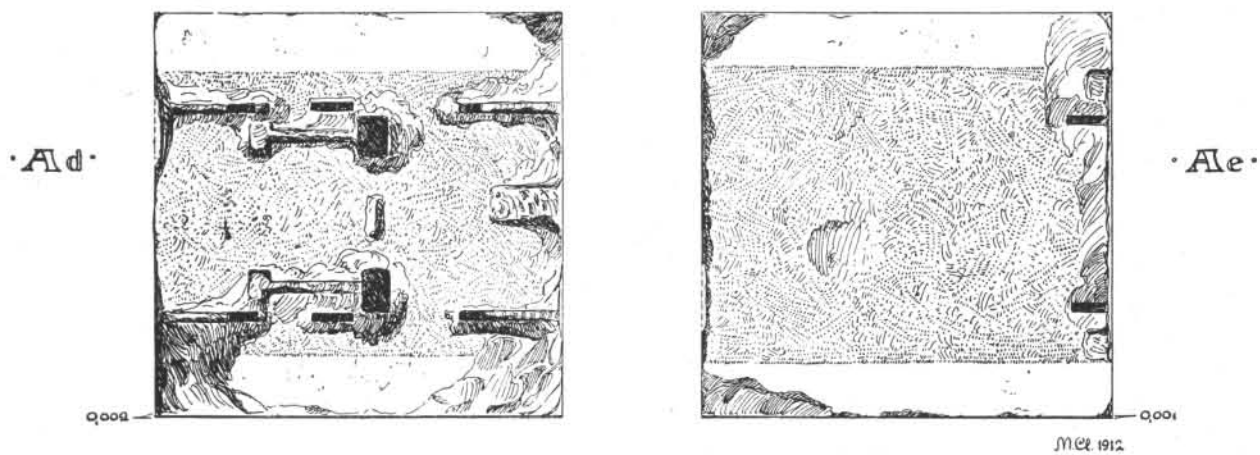
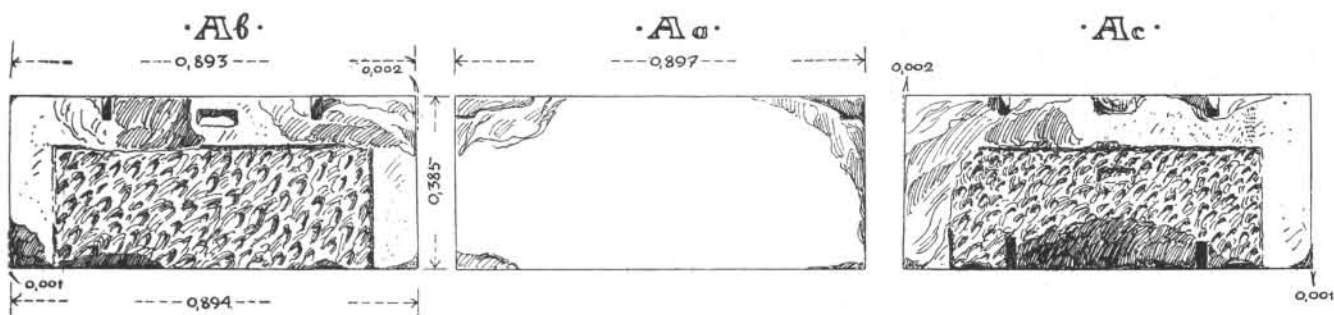

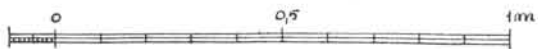
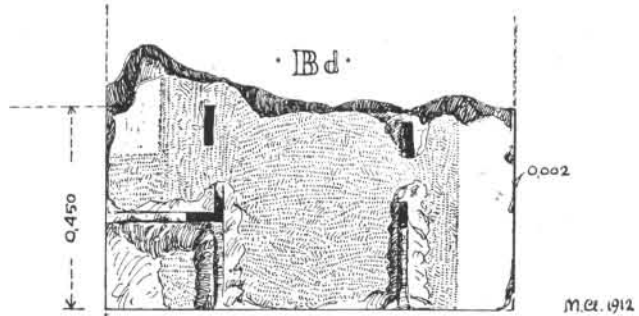
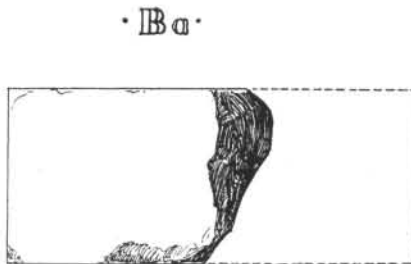
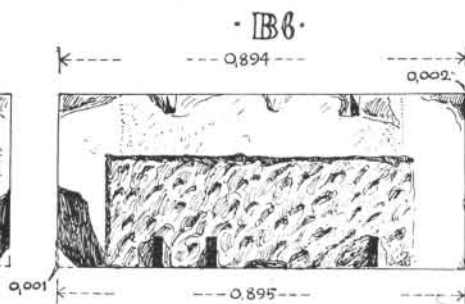
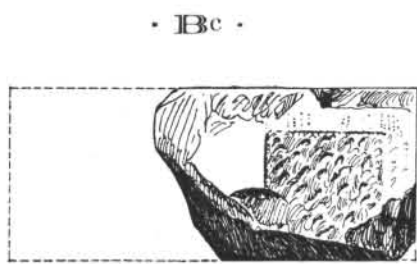
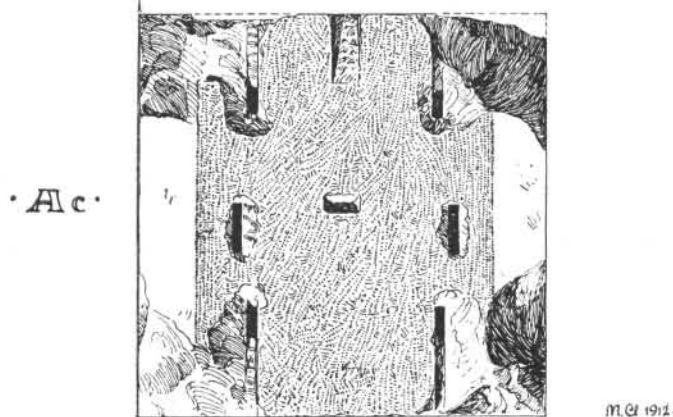
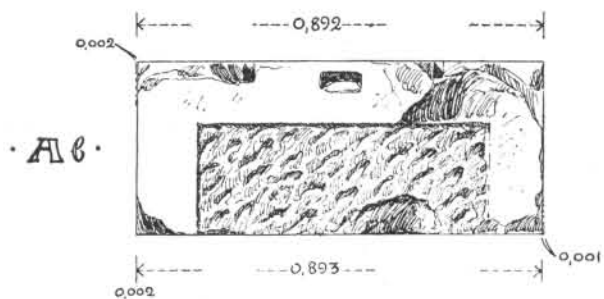
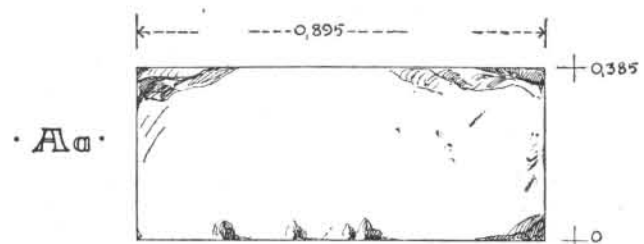

PARPAINGS.

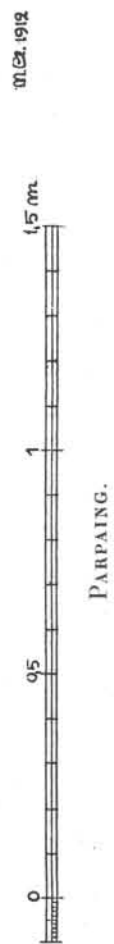
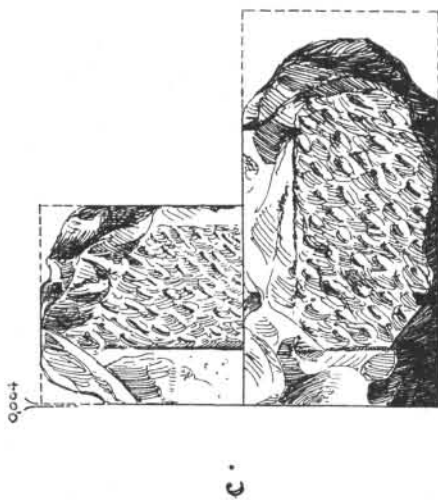
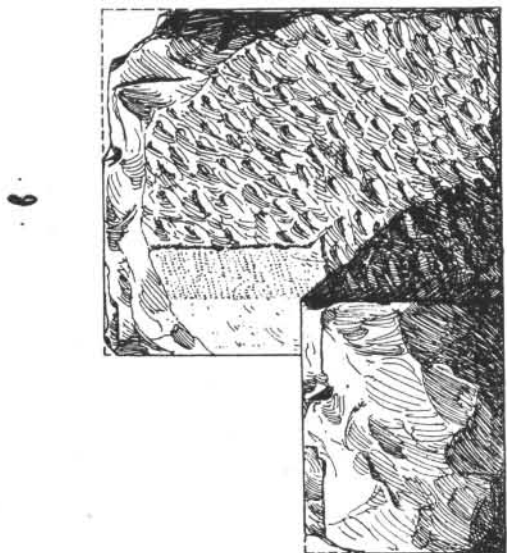
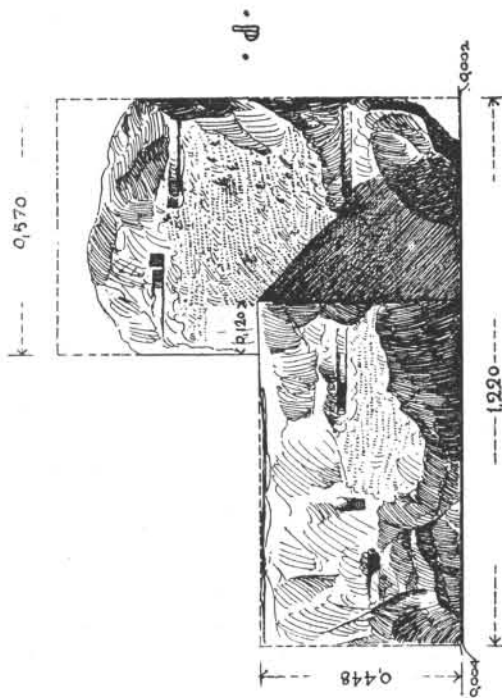
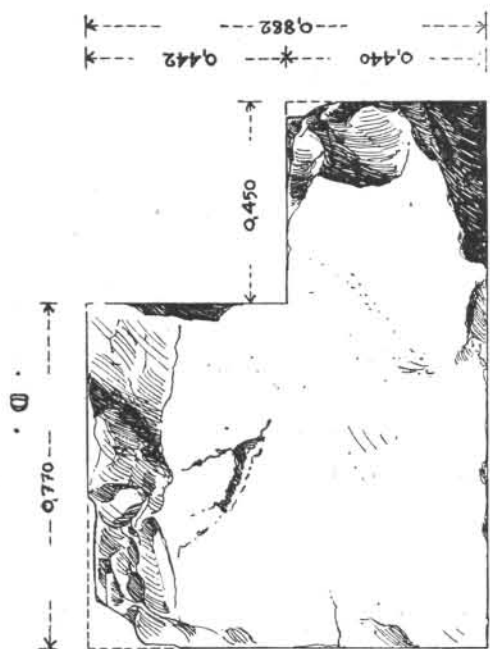

· c ·

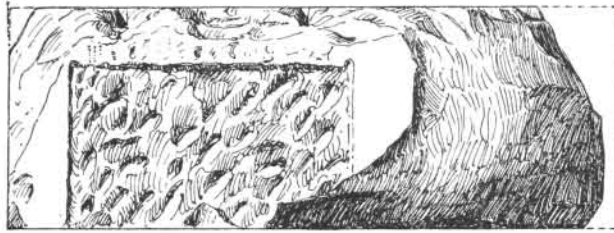

· a ·



+ 0,495

+ 0



· b ·

· d ·

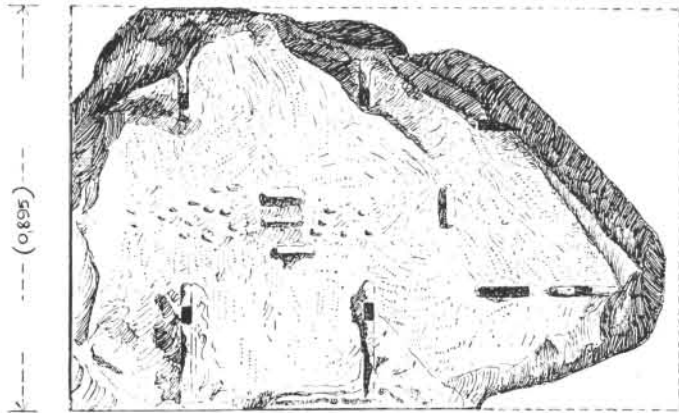

· e ·

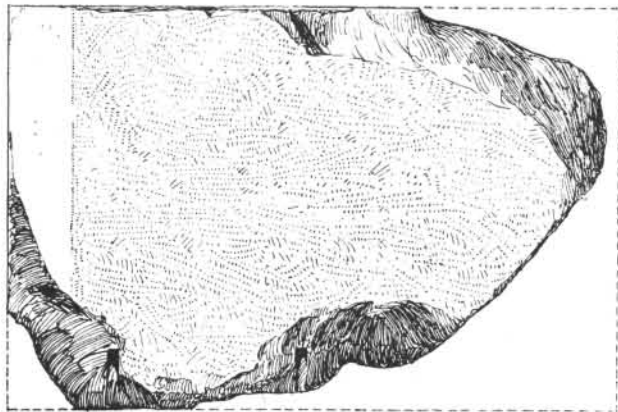

M. Et. 1912.



PAR PAING.

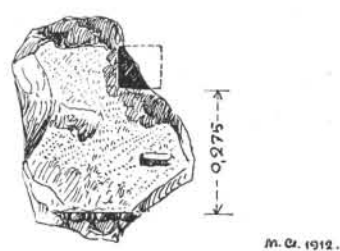
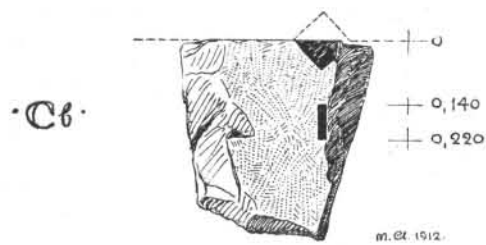
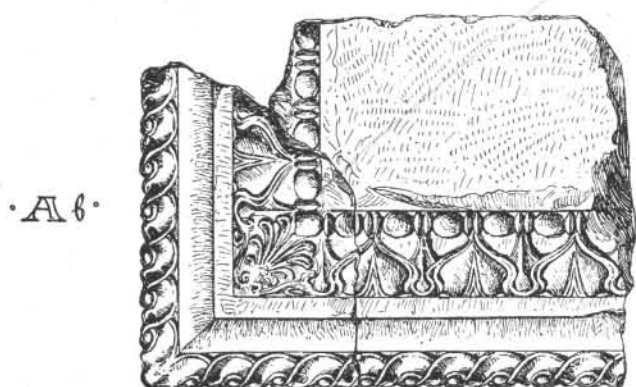
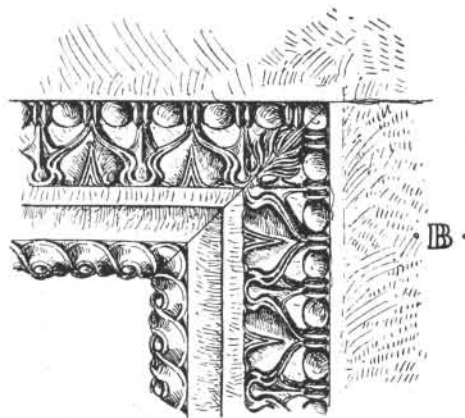
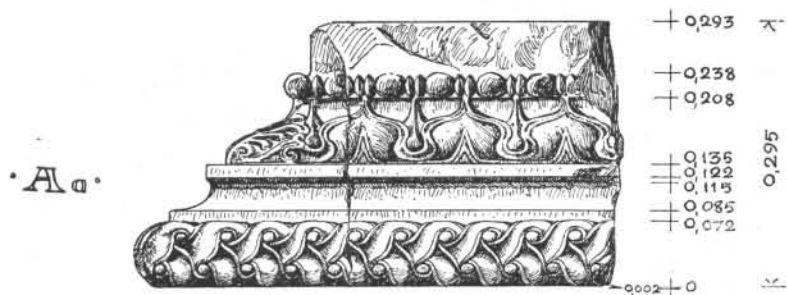

FRAGMENTS DE LA BASE INTÉRIEURE DU MUR DE LA CELLA (ASSISE SUPÉRIEURE DU TOICHOBATE).

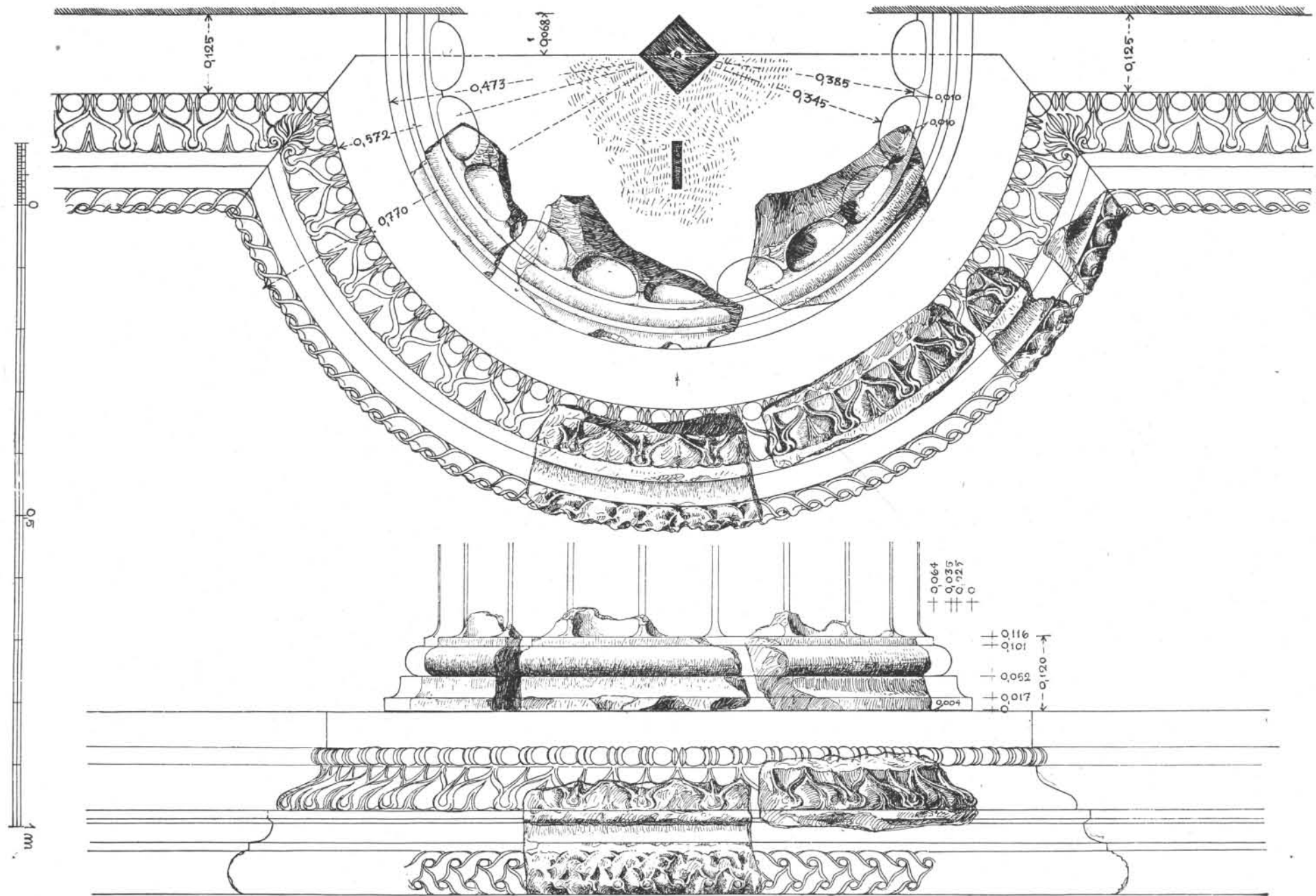

FRAGMENTS DE LA DEMI-COLONNE INTÉRIEURE ET DE L'ASSISE SUPÉRIEURE DU TOICHORATE.

Nogens Clemmensen. 1913.

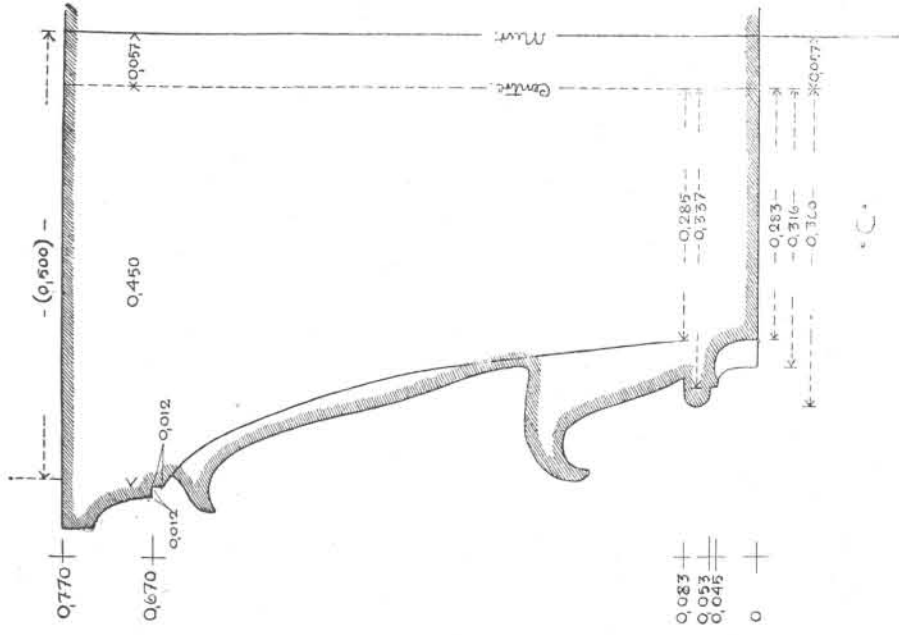

Mogens Clemmensen. 1913.

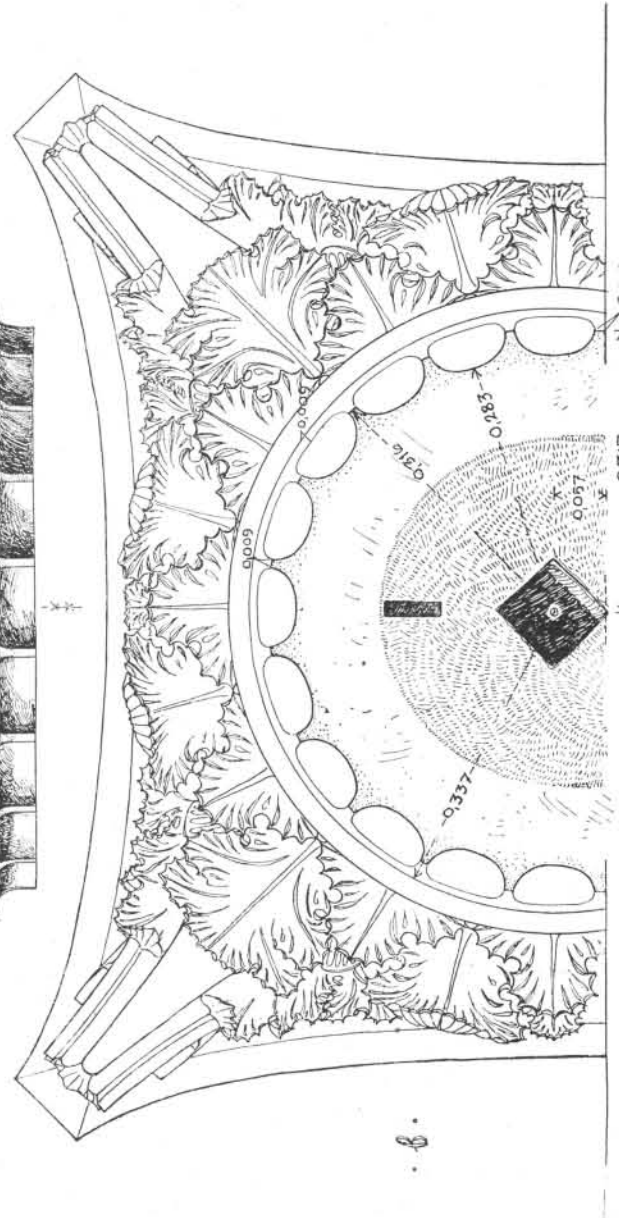
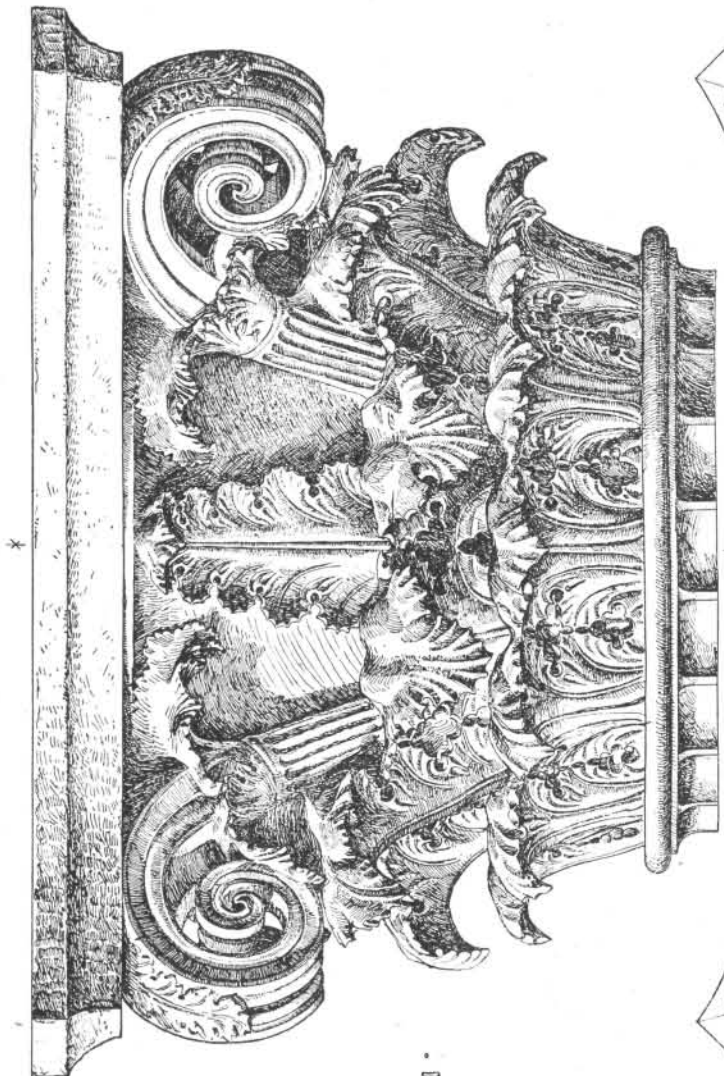

CHAPITEAU DE L'ORDRE INTÉRIEUR.

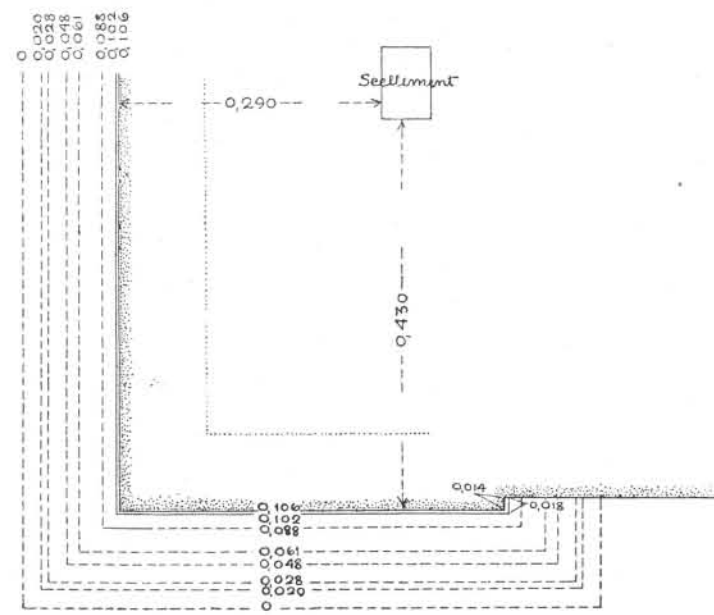
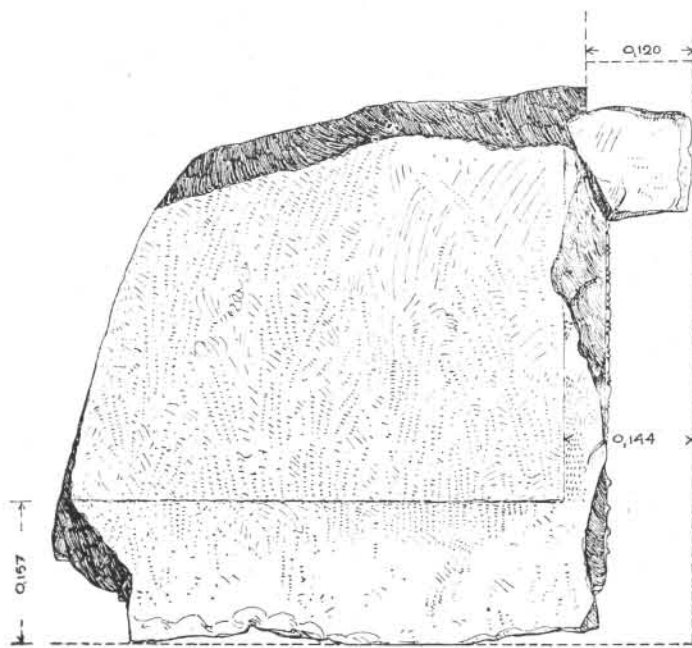
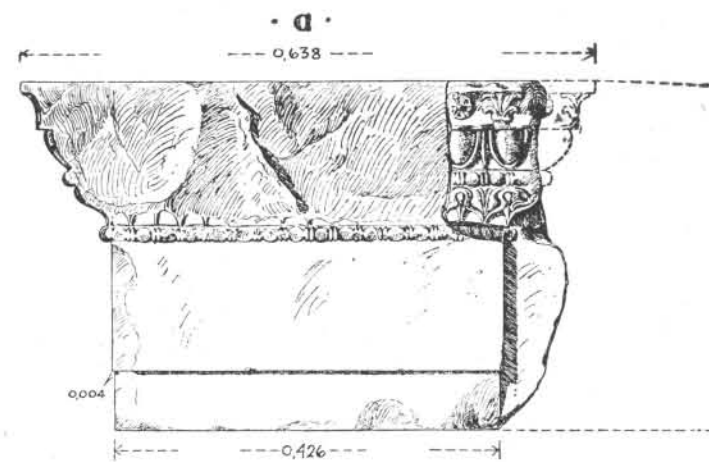
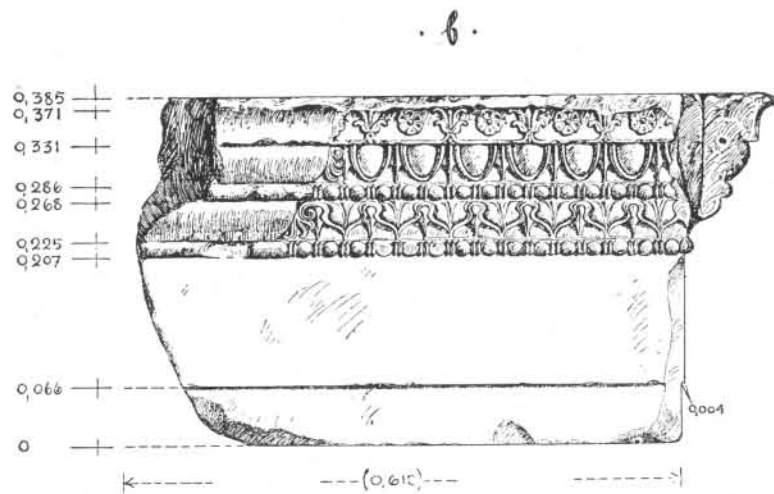

Norges Clemmensen. 1915

CHAPITEAU DU PILASTRE INTÉRIEUR.

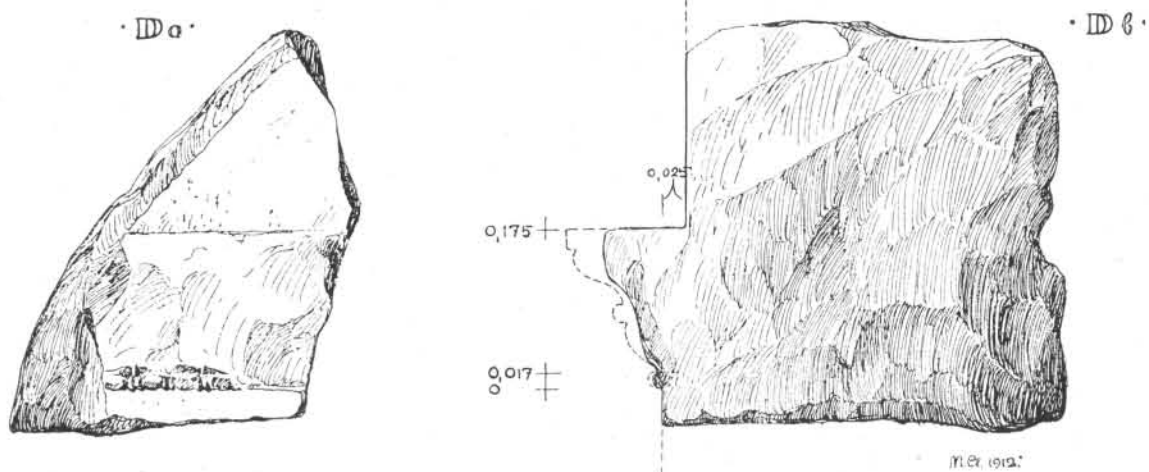
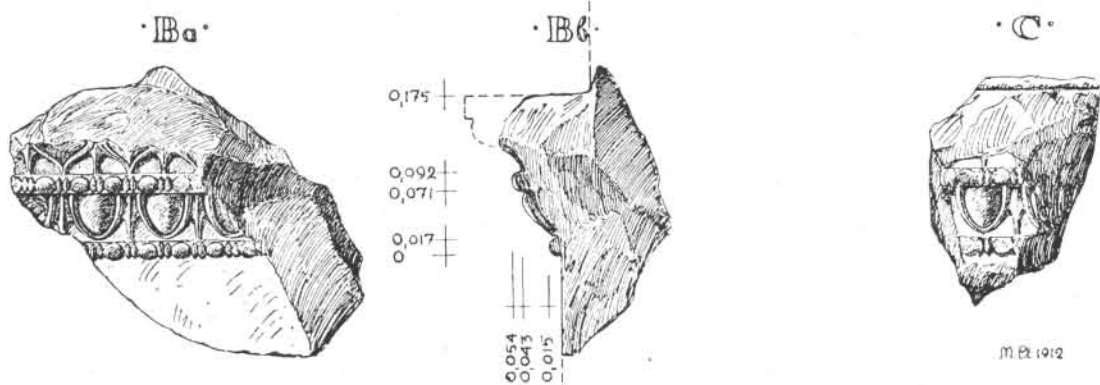
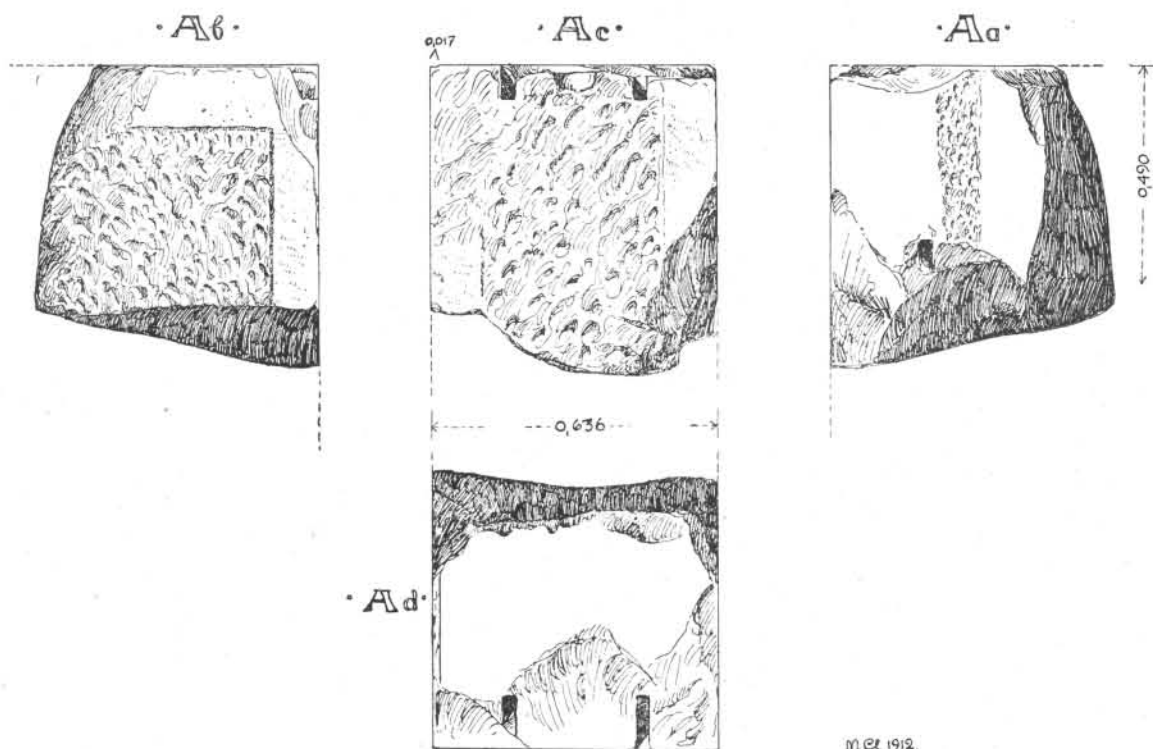

FRAGMENTS DE L'ARCHITRAVE DE L'ORDRE INTÉRIEUR.

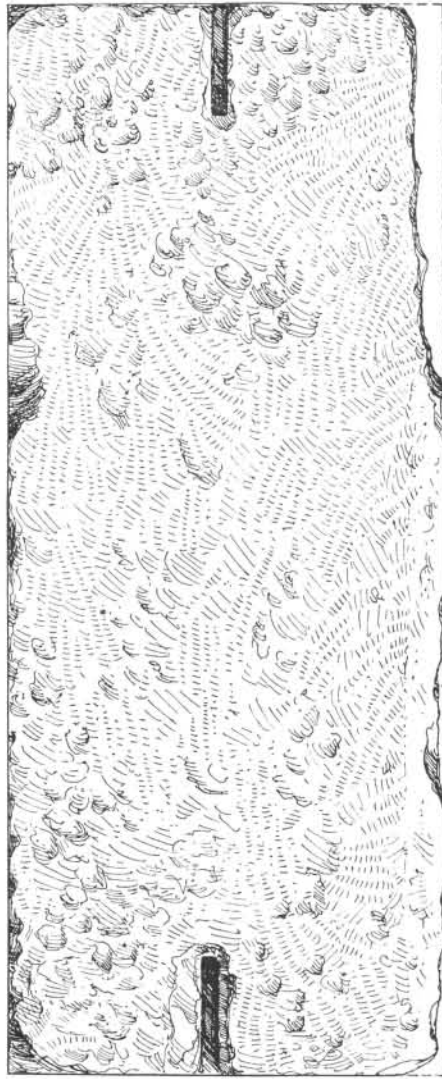
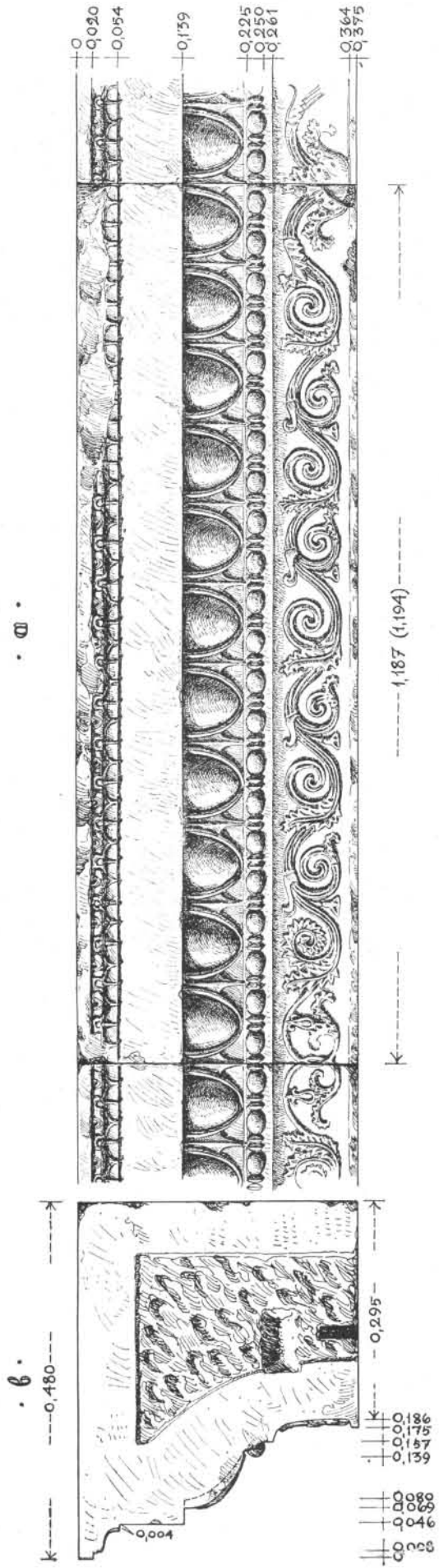

COURONNEMENT INTÉRIEUR DU MUR DE LA CELLA.

Mogens Elménen. 1913.

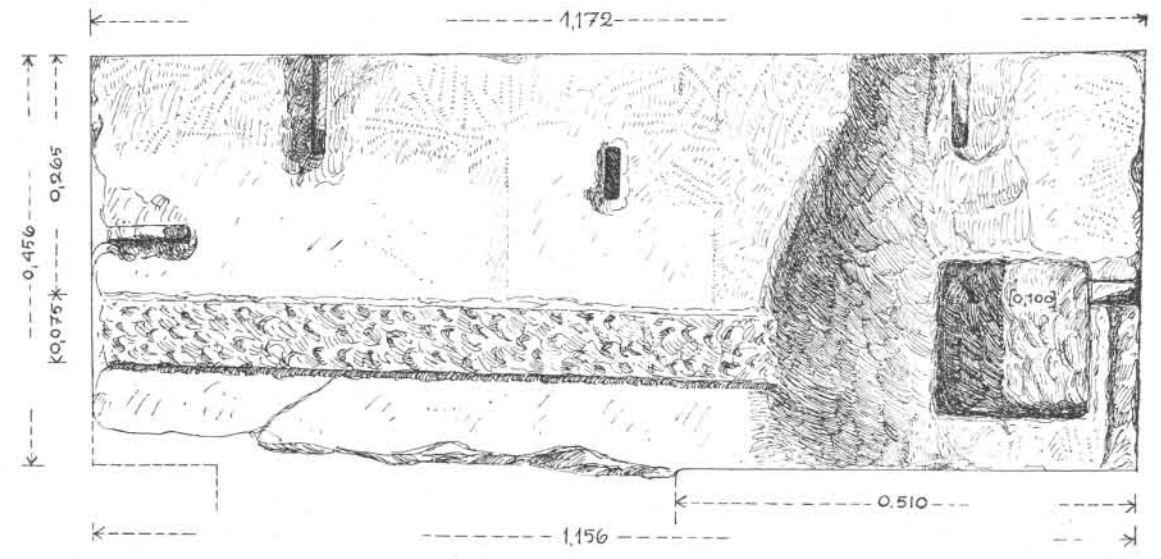
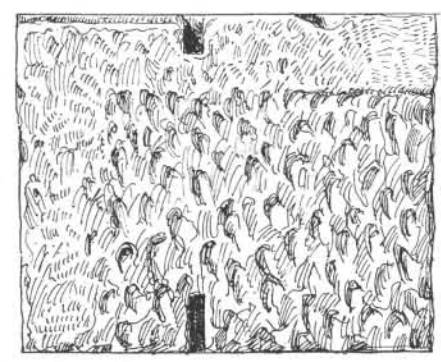
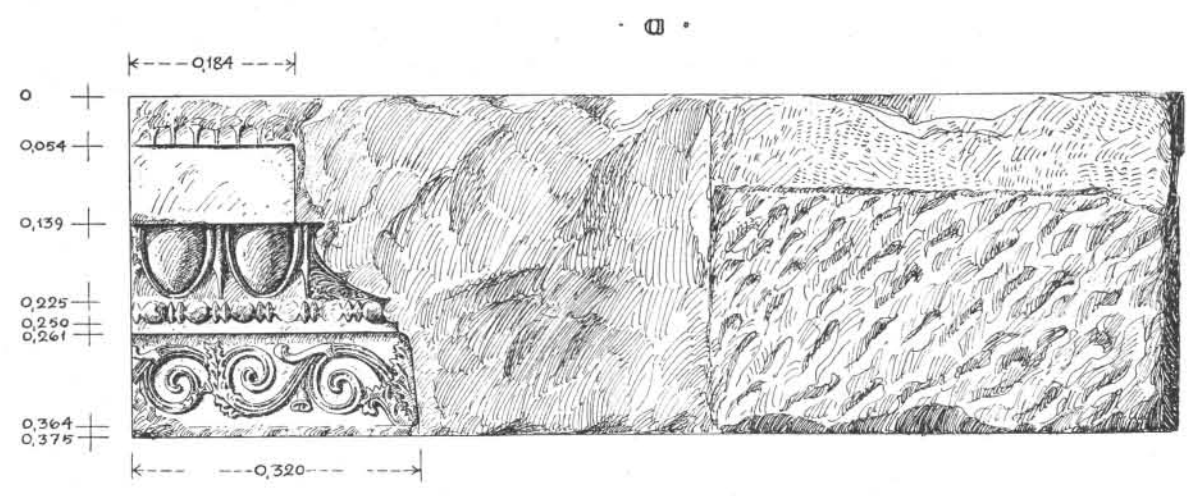
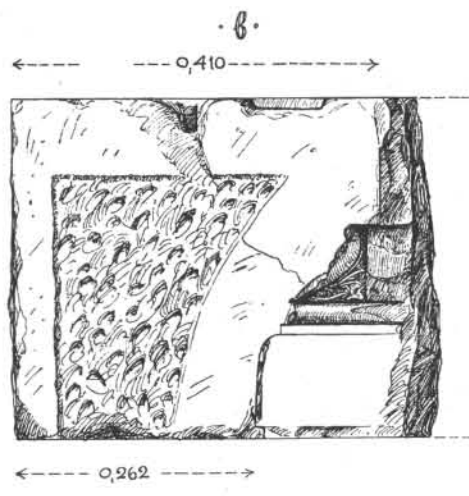

Mogens Clemmensen. 1913.



COURONNEMENT INTÉRIEUR DU MUR DE LA CELLA.

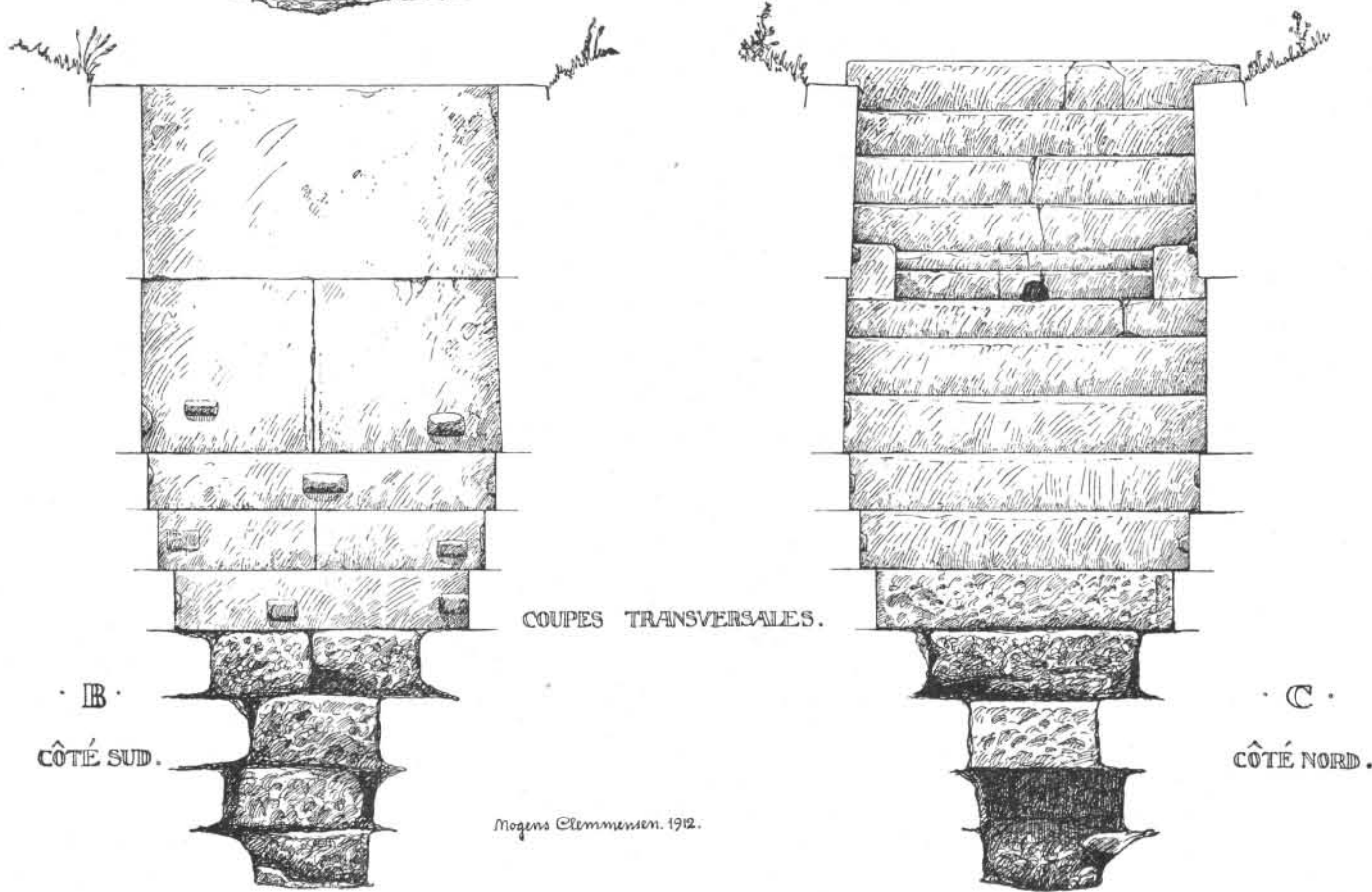
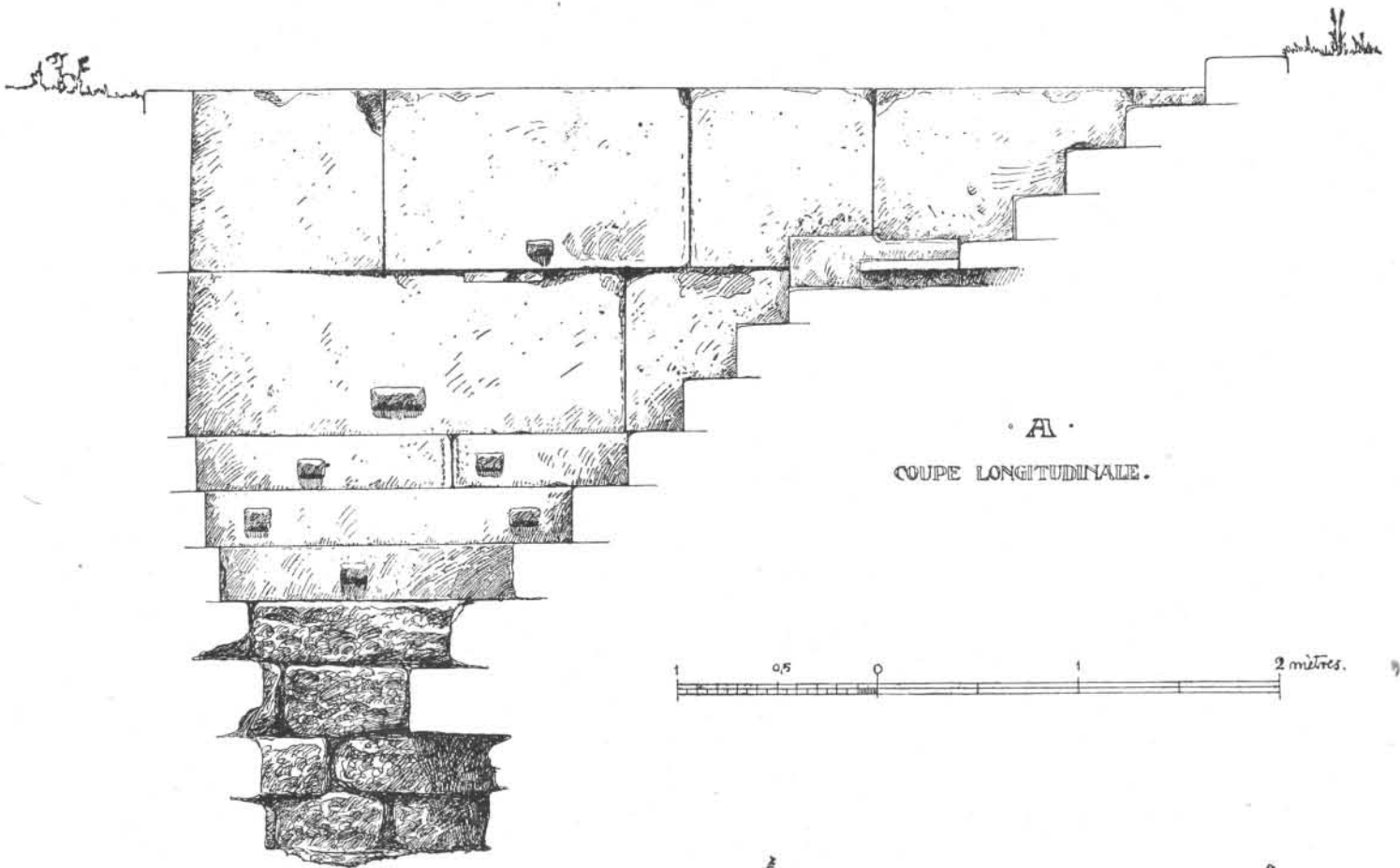

LA FONTAINE.



A



B

Le temple d'Aléa Athéna.



A

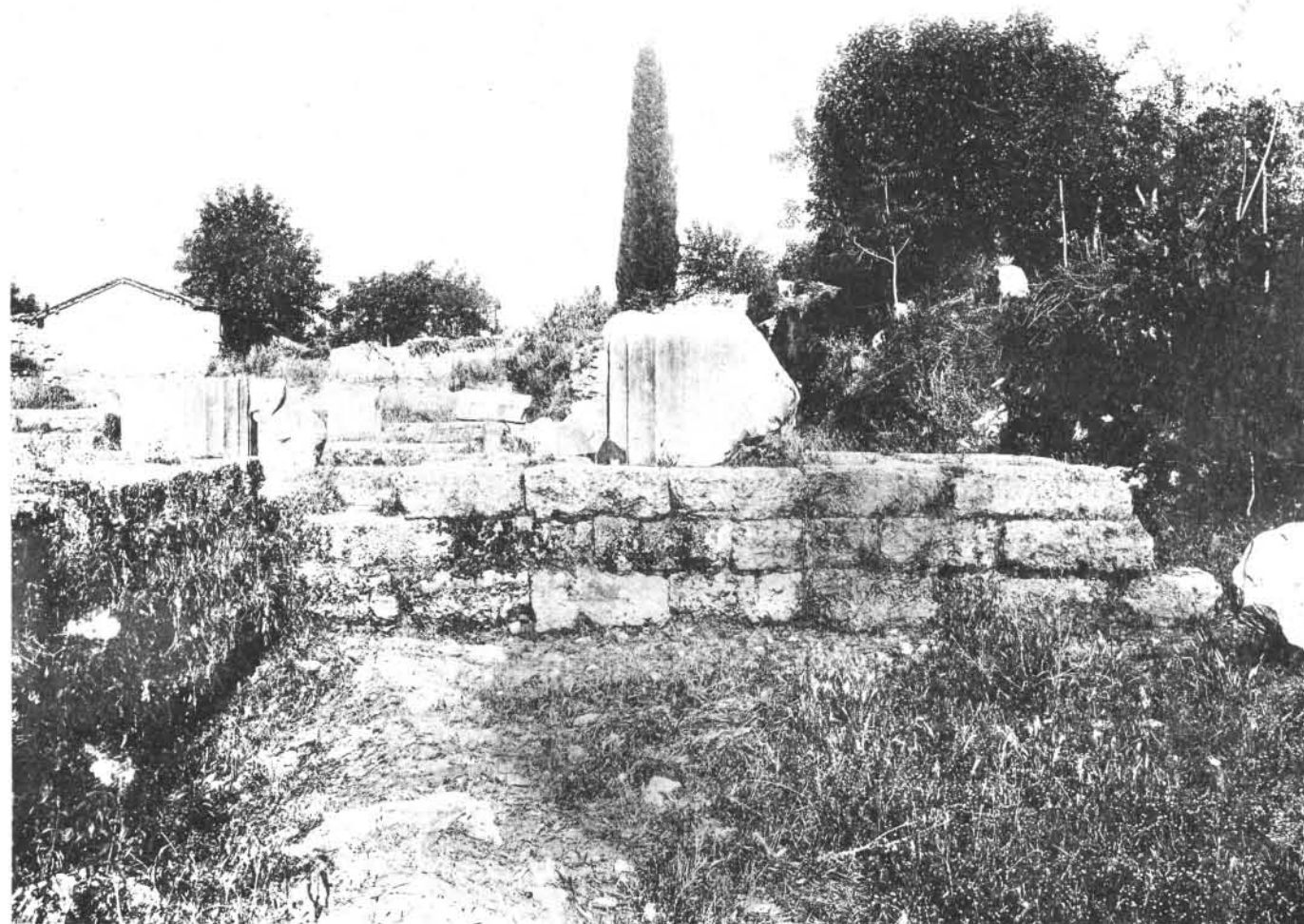

B

Le temple d'Aléa Athéna.



A



B

Vues de l'intérieur du temple.

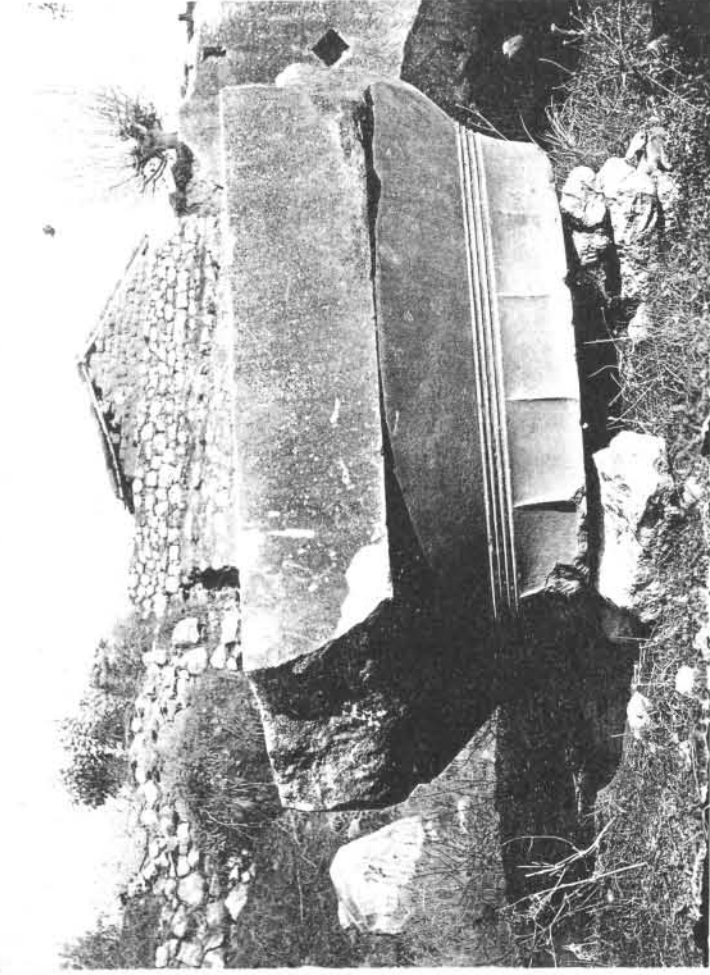

B



D



A



C

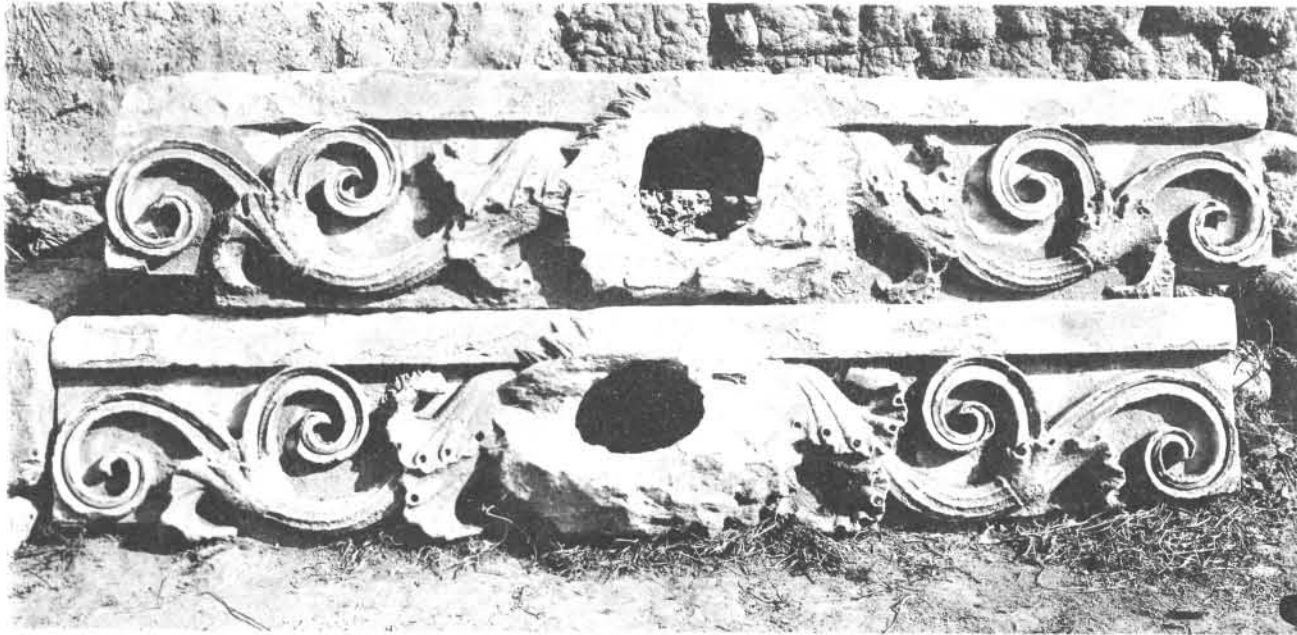

A



B

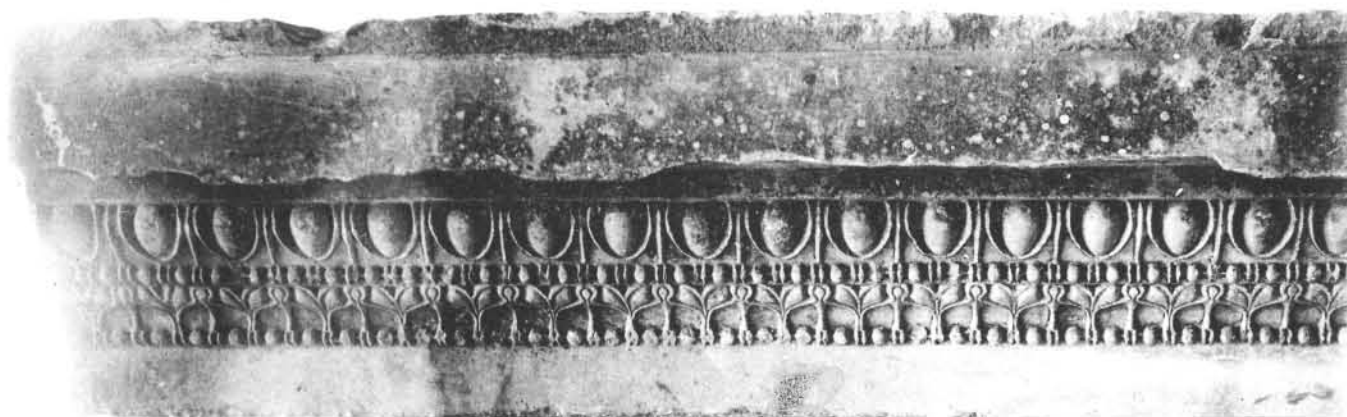

C

Sima du temple de Némée et morceaux d'architecture.



A



B



C

Temple de Némée et fragments d'architecture.

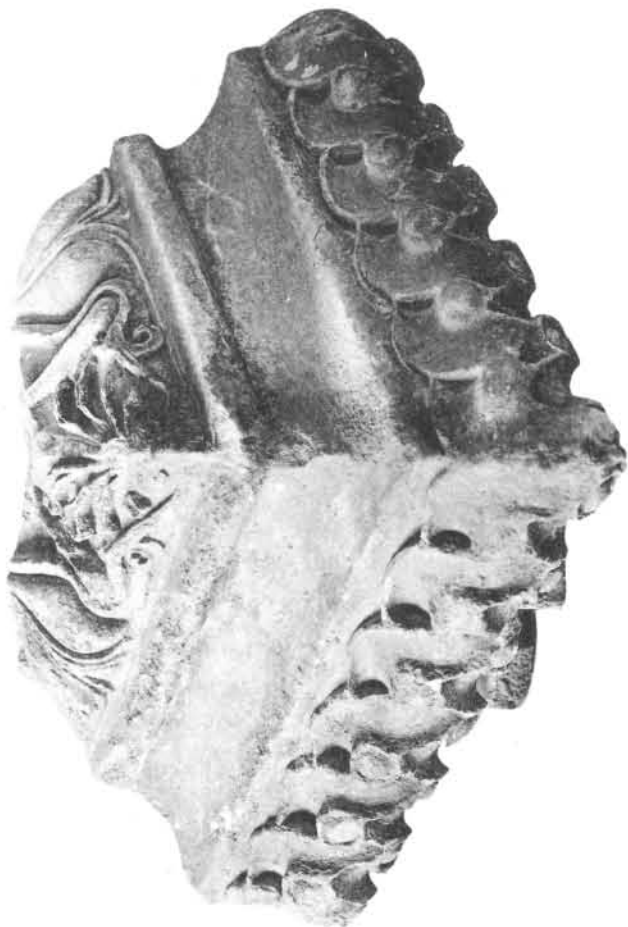

B



D

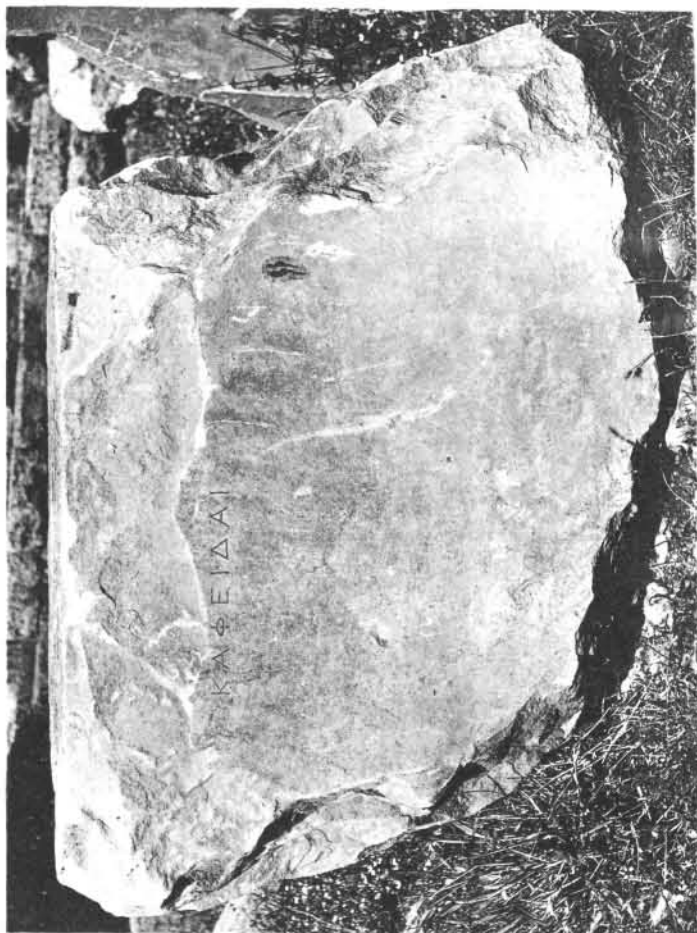

A



C

Fragments d'architecture.

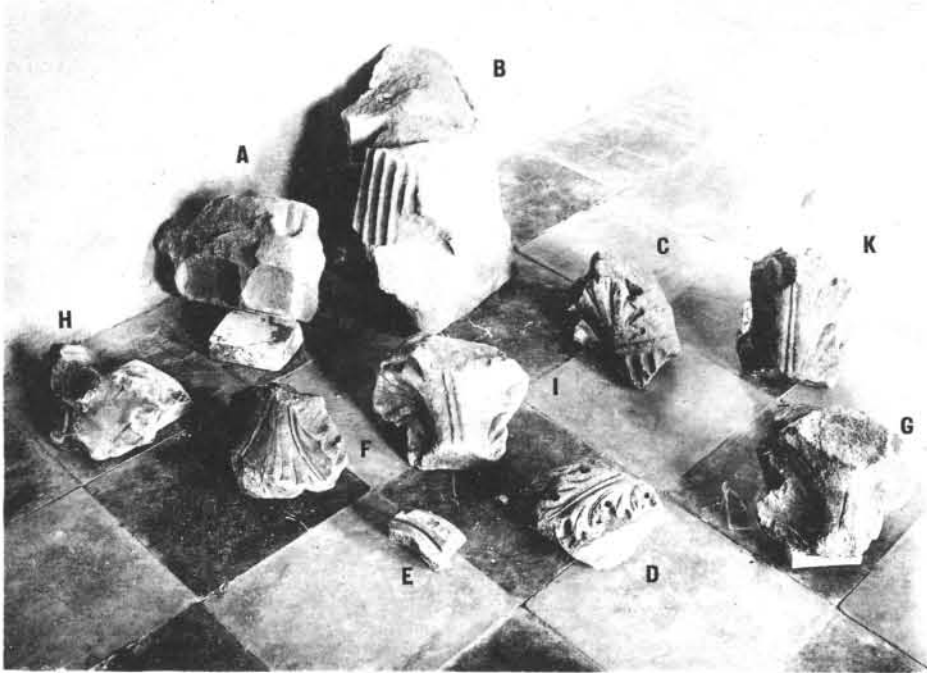

A

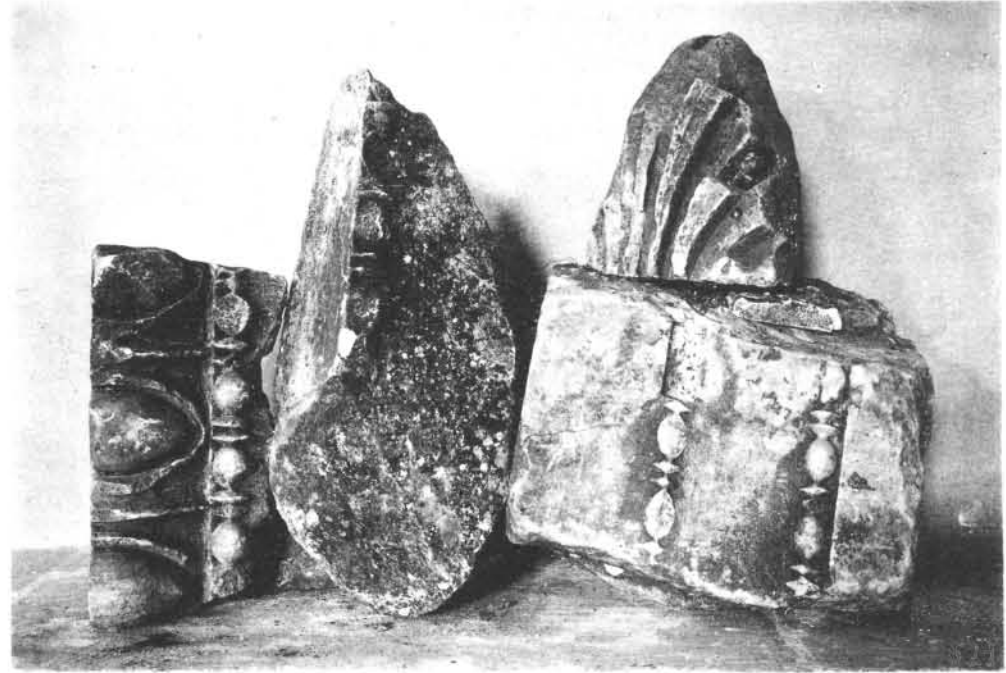

B

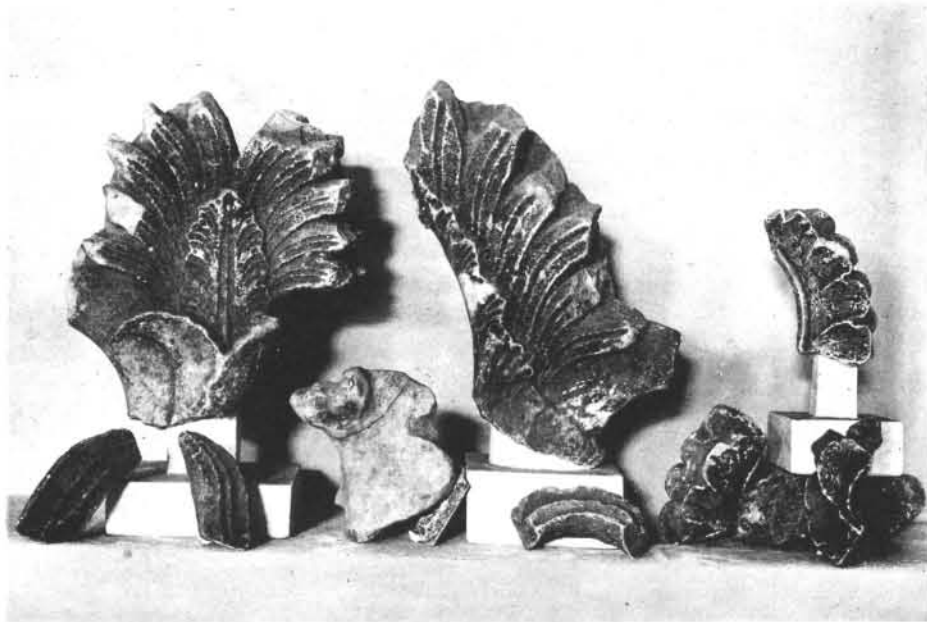

C

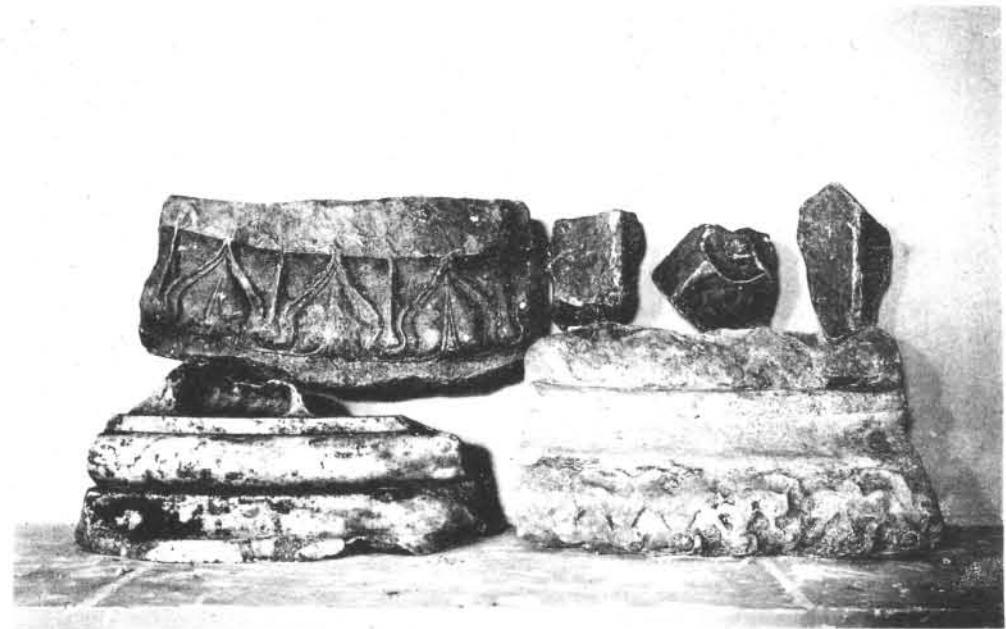

D

Fragments du chapiteau corinthien et de la décoration architecturale.



A (N)



B (L)



C (M)



D



A



B



C

Le chapiteau de l'ordre intérieur (reconstitution).

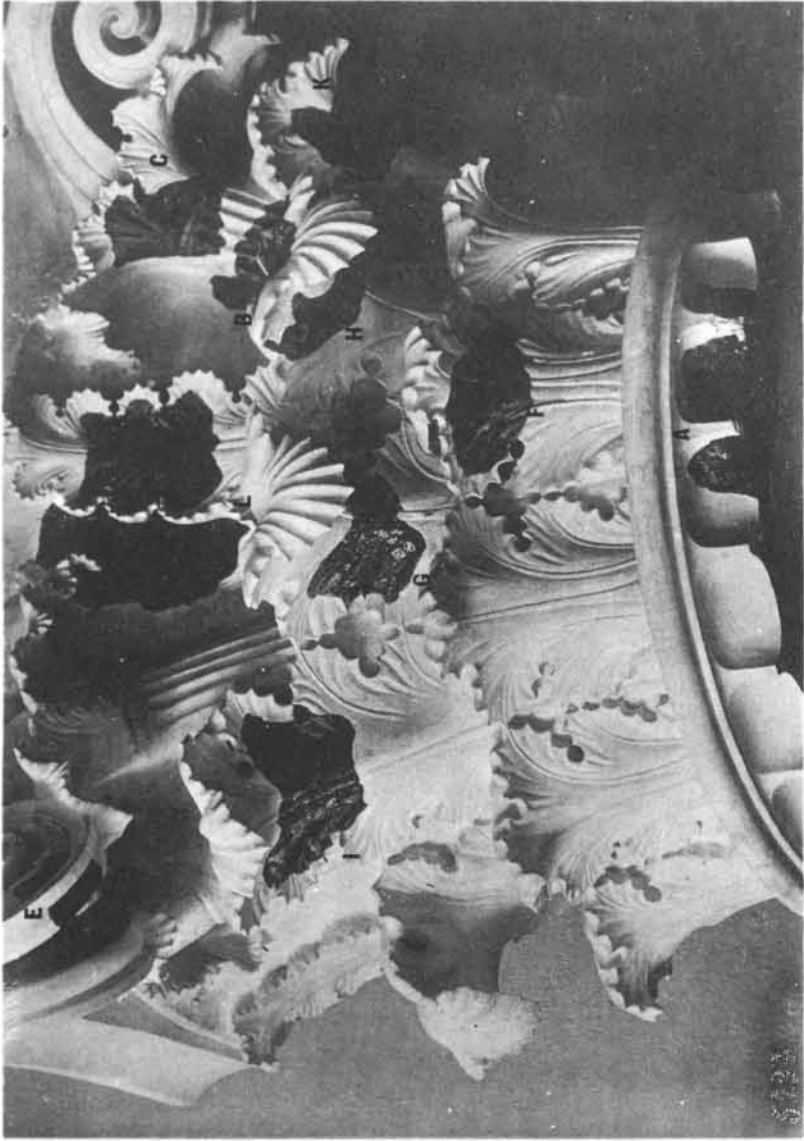

B



D



A



C

Le chapiteau de l'ordre intérieur (reconstitution).



A



B

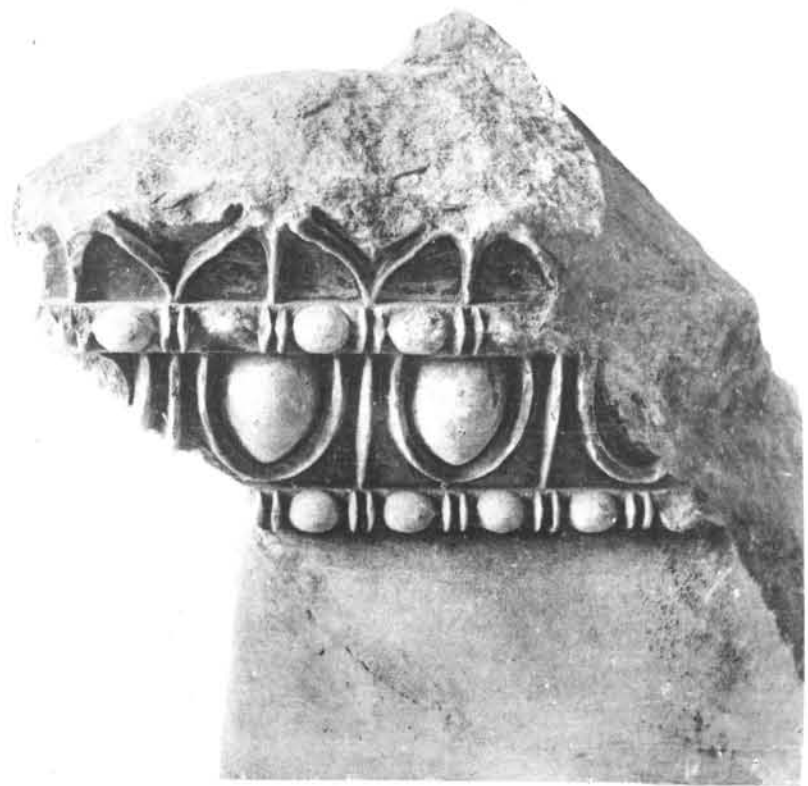

C

Fragments de la décoration architecturale (intérieur du temple).



A



B

Le temple de Bassai.



A



B



C



D

Fondations du temple, restes de l'autel et vues de la fontaine.



A (I)

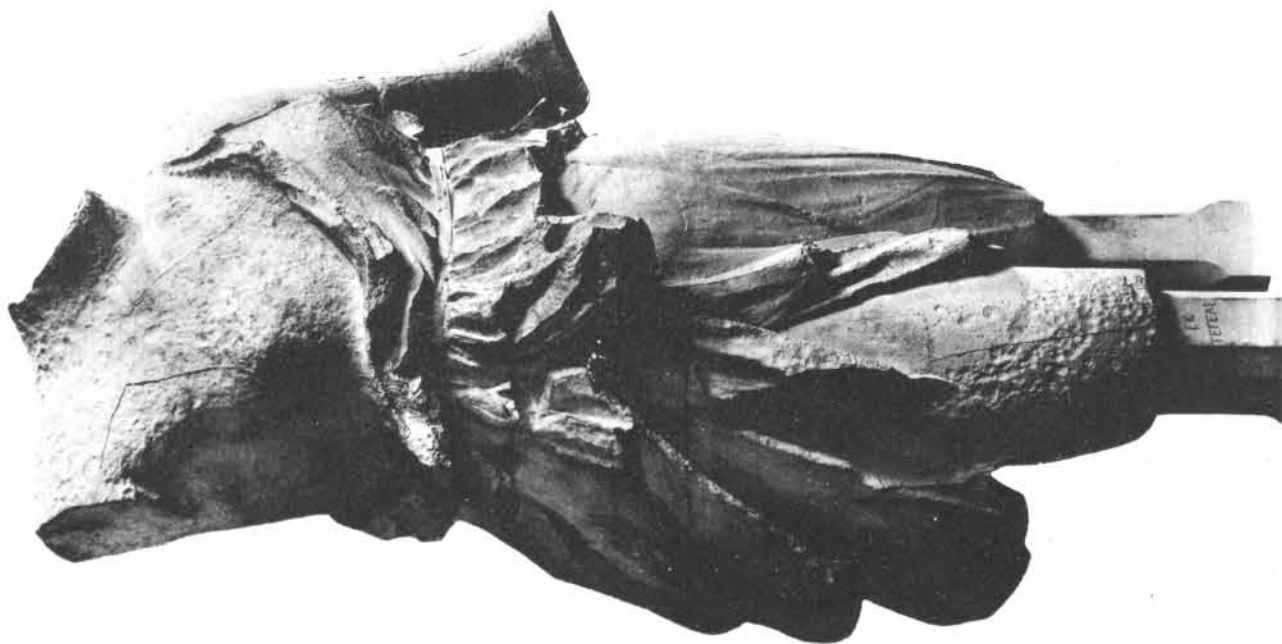

B (I)

Torse d'Atalante.



B (1)

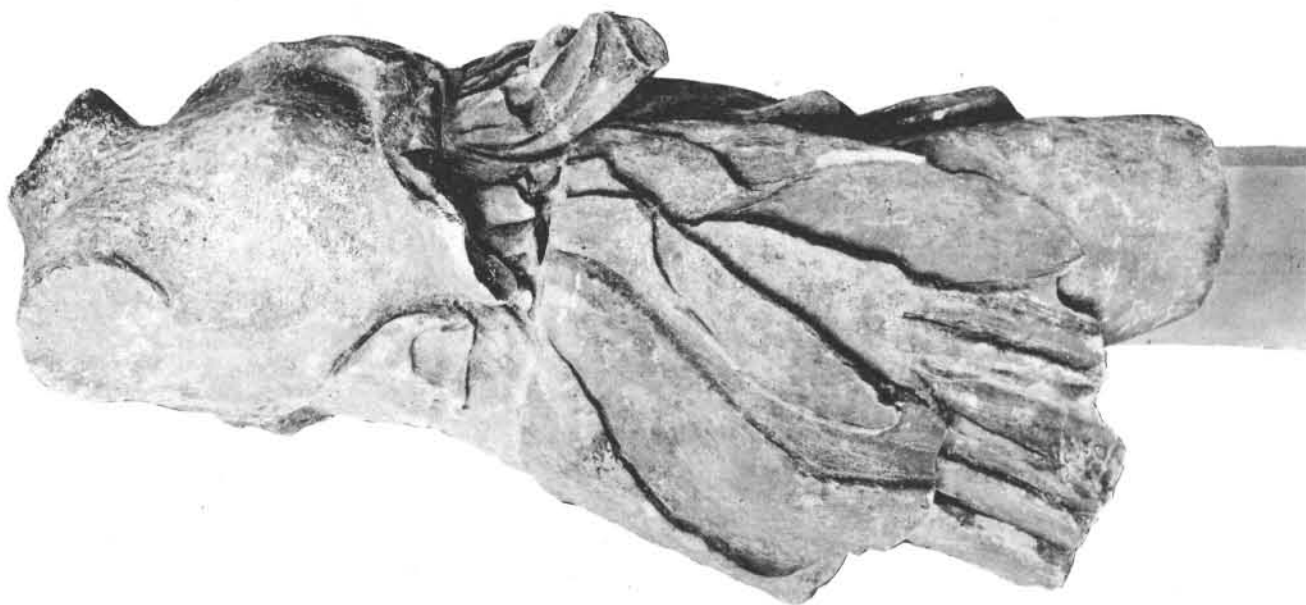

A (1)

Torse d'Atalante.



A (1)



B (53)



C (28)

Torse d'Atalante et fragments d'Athènes.



B (8)



A (7)

Tête d'Héraclès et tête casquée.



A (7)



B (7)



C (7)



D (18)

Tête d'Héraclès et fragment de tête masculine.



A (8)



B (8)



C (19)



D (19)

Tête casquée et fragment de tête masculine.



A (9)



B (17)

Tête casquée et tête de jeune homme d'Athènes.

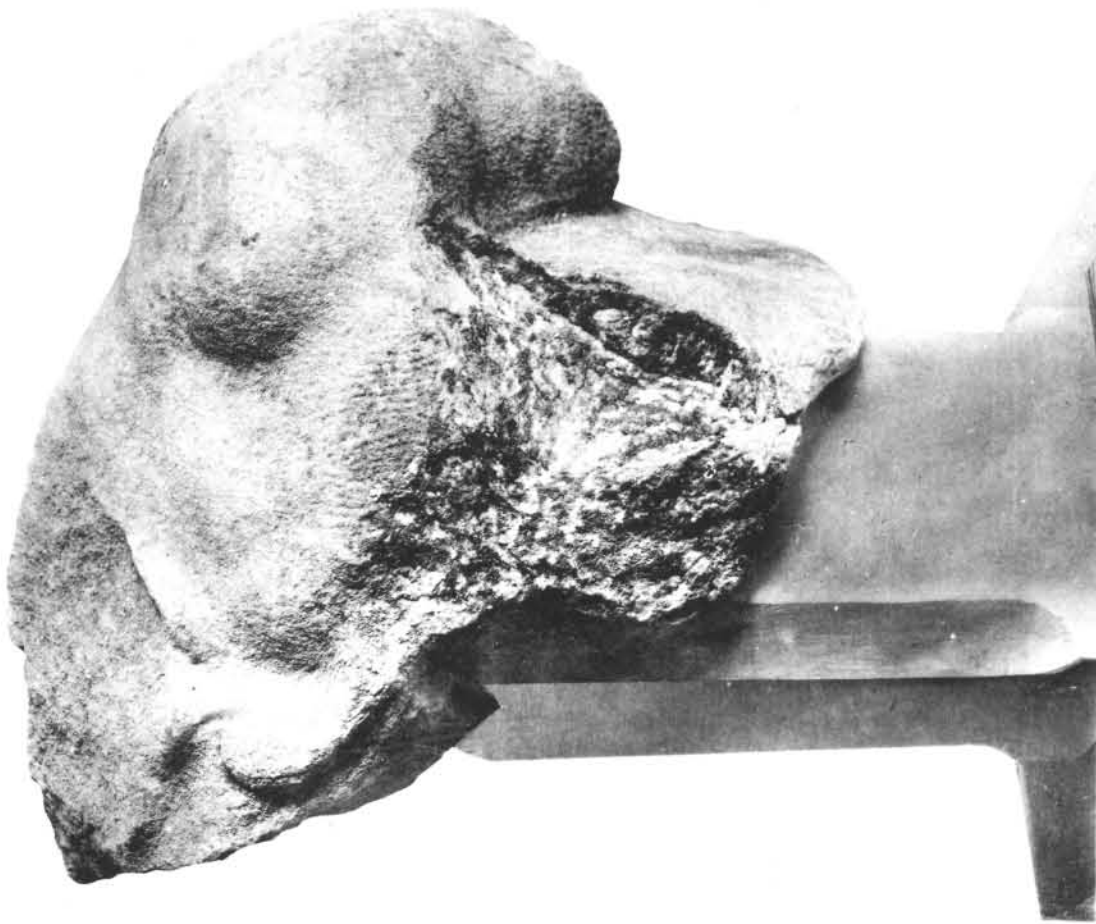

A (22)



B (22)

Fragment de figure masculine.

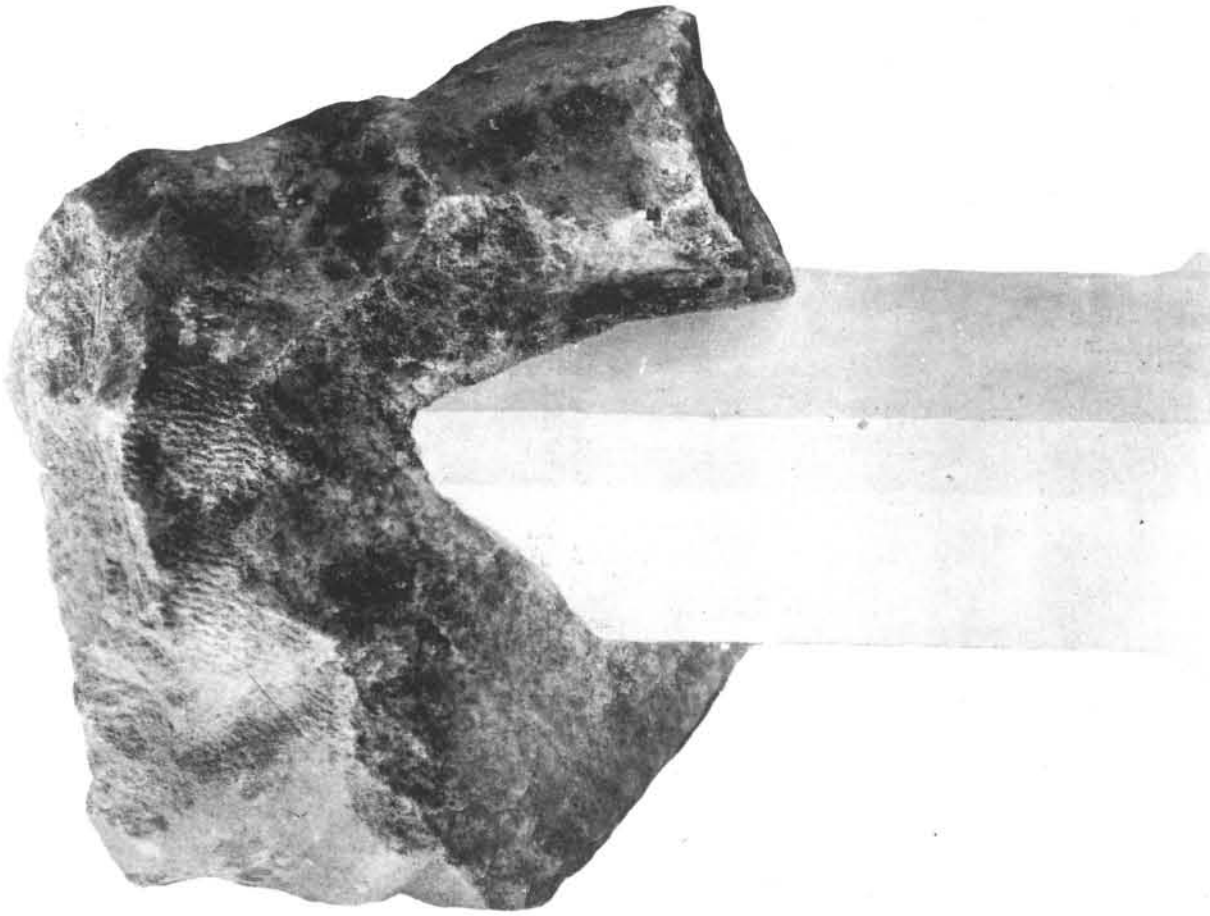

A (23)

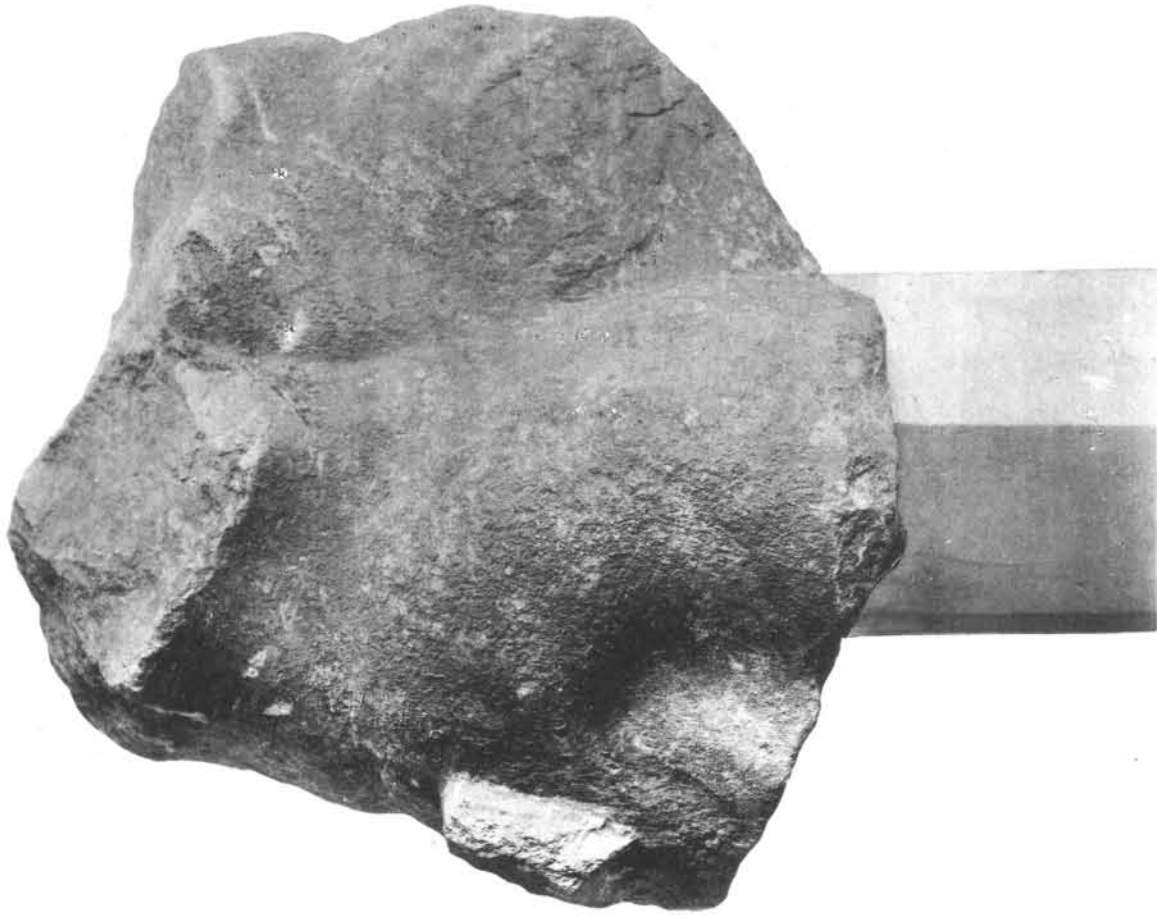

B (23)

Fragment de figure masculine.



A (21)



B (21)



C (24)



D (24)

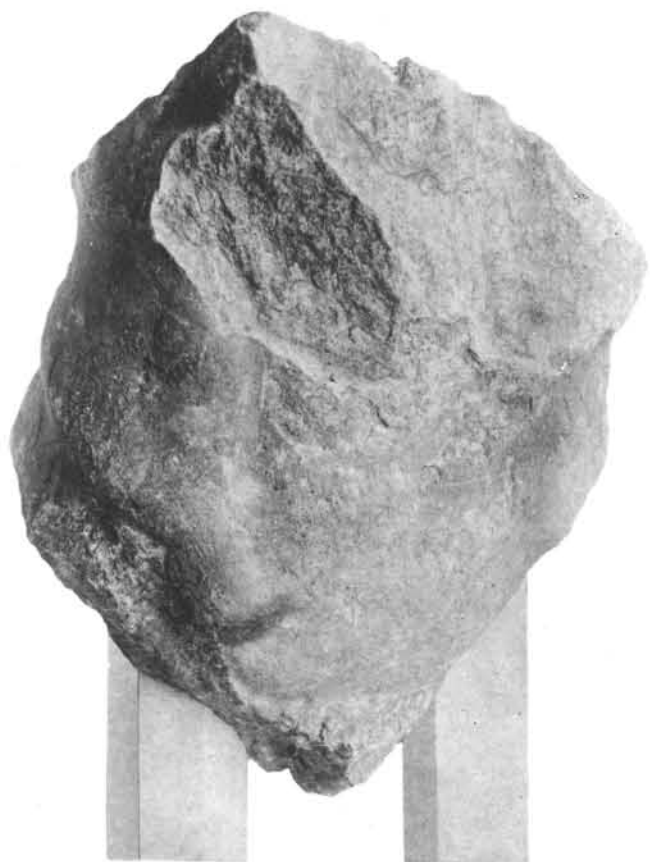

A (25)



B (25)



(C 6)



(D 6)

Fragments de sculptures.

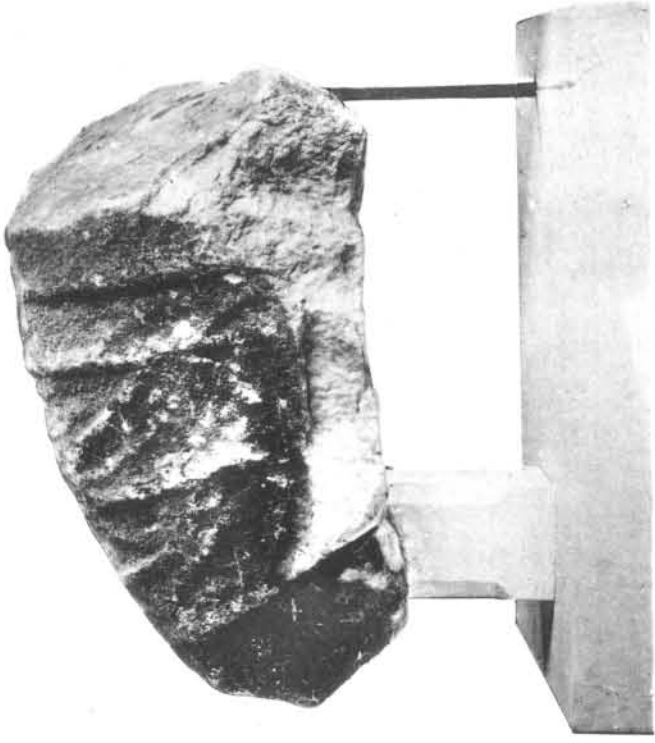

B (55)

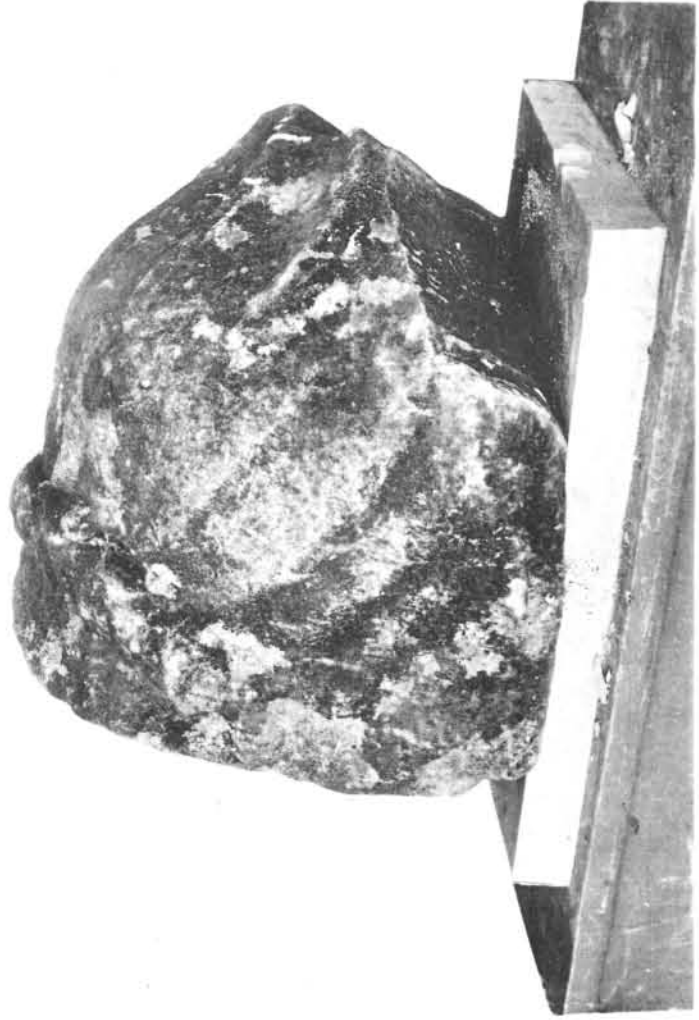

B (10)



A (55)

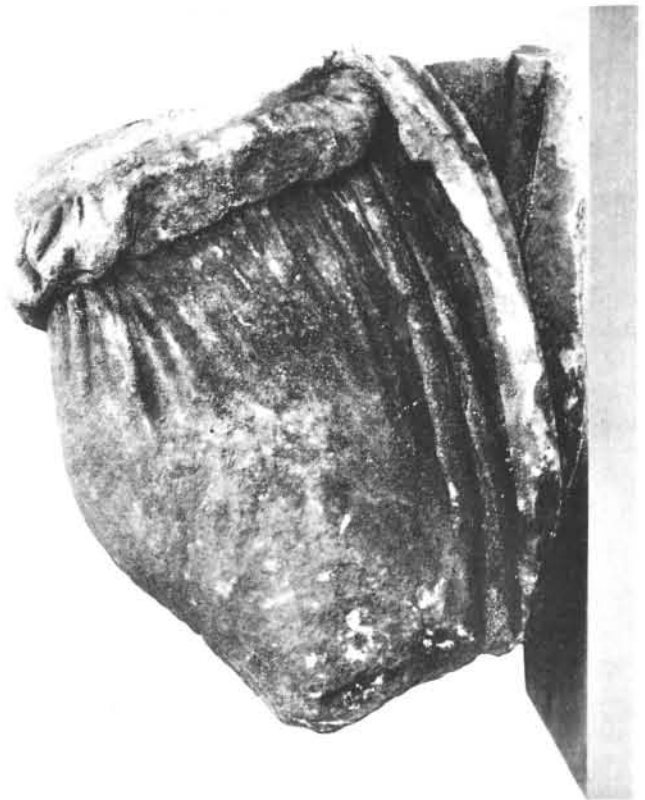

C (10)

Fragments de sculptures.



A (3)



B (57)



C (54)



A (69)



B (26)



C (71)



D (71)



E (70)



F (5)



G (5)



H (58)



63



42



101



60



29

A



59



61



31



38



105

B



73



2



76



86



62

C

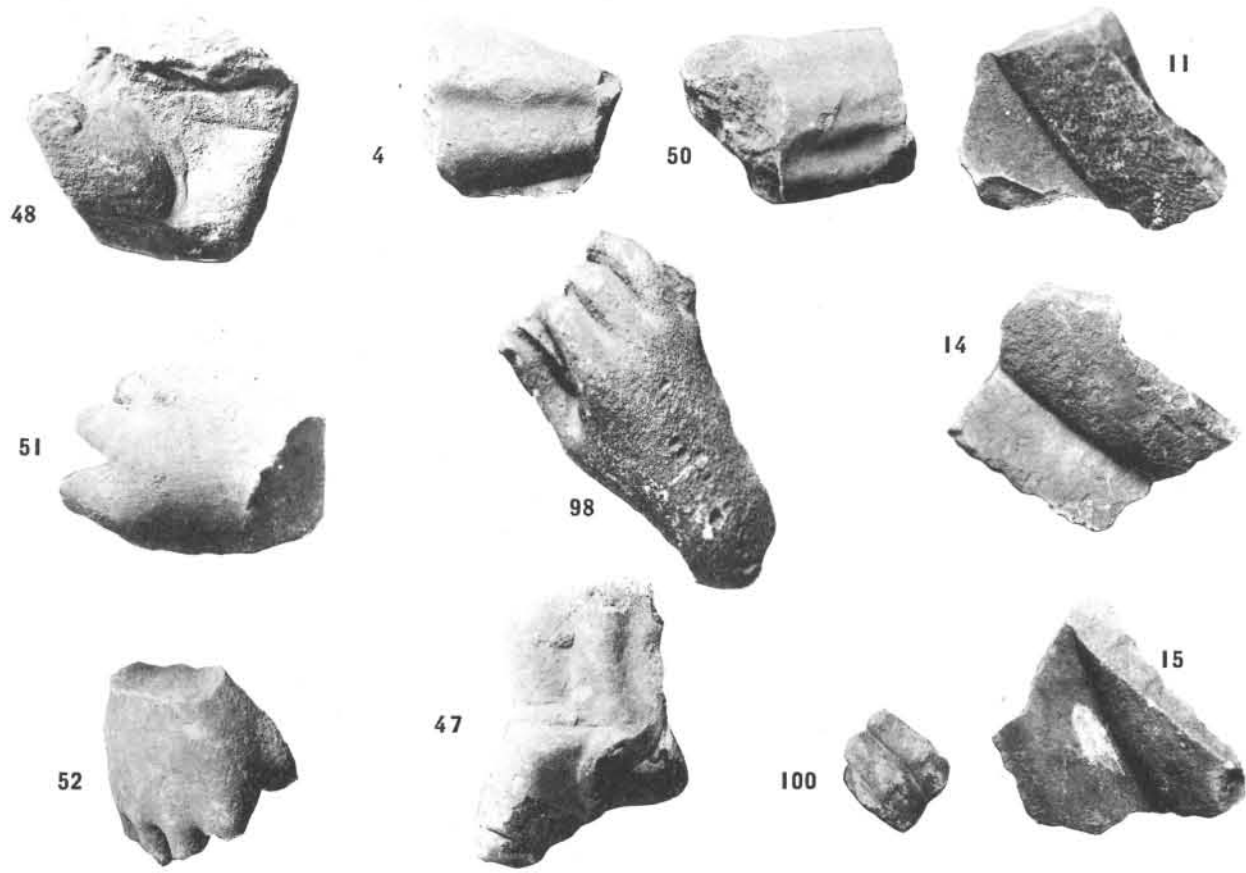

A

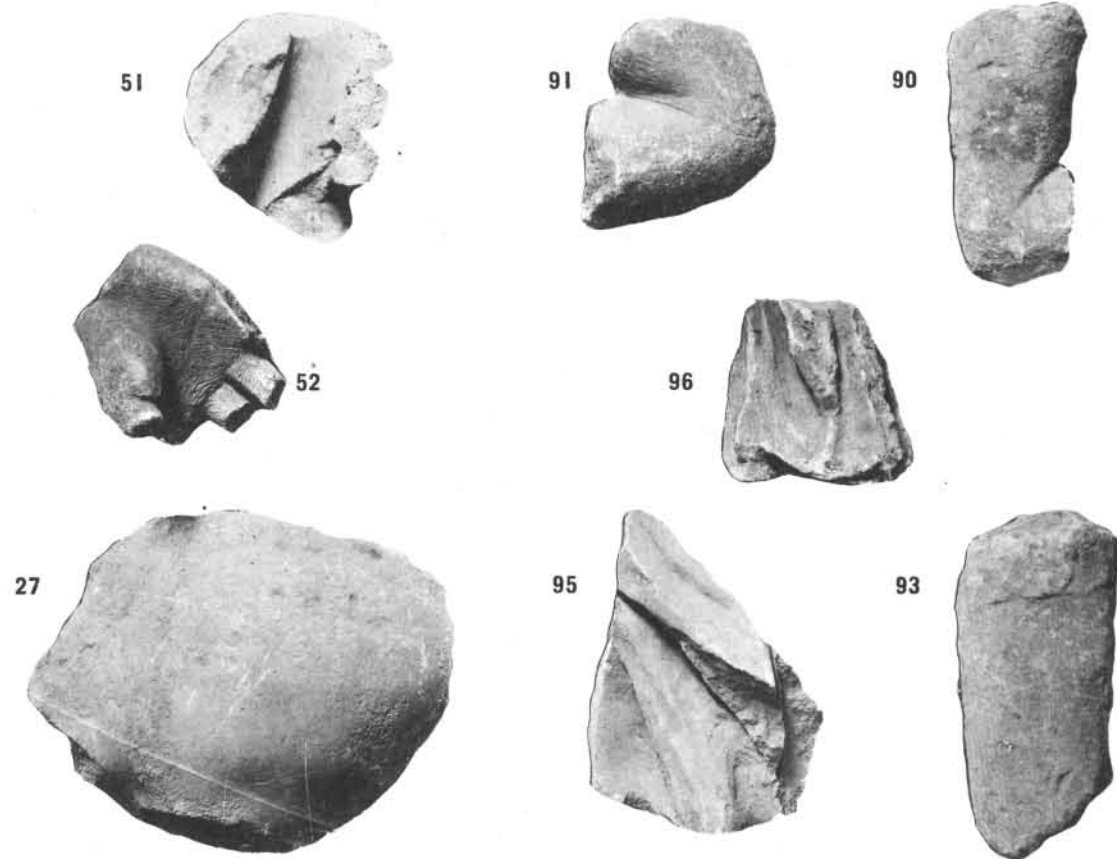

B

Fragments de sculptures.



A (56)



B (20)



C (103)



D

Fragments de sculptures et sarcophage de Prévéza.



B (97)



A (97)

Tête féminine.



B (104)



C (99)



A (97)

Tête féminine et fragments de sculptures.



A (97)



B (98)



C (102)



D (102)

Tête féminine et fragments de sculptures.



B (106)

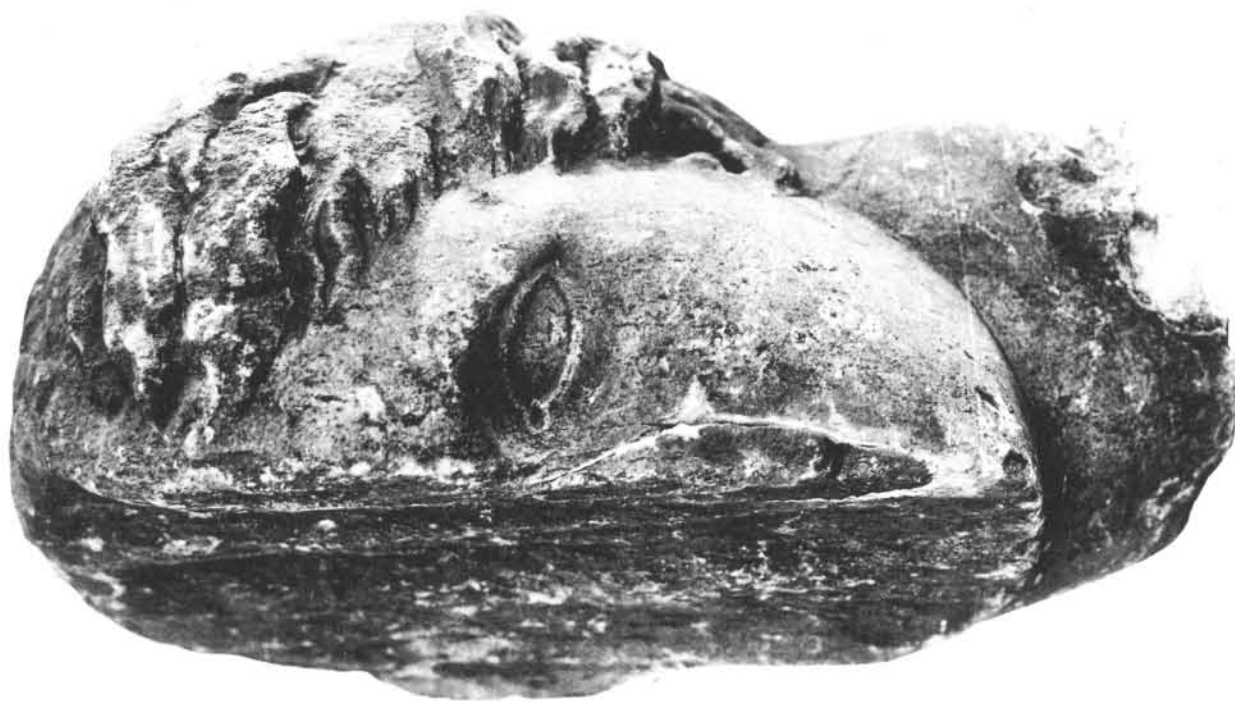

A (106)

Tête féminine.

